



US006067290A

United States Patent [19]
Paulraj et al.

[11] **Patent Number:** **6,067,290**
[45] **Date of Patent:** **May 23, 2000**

- [54] **SPATIAL MULTIPLEXING IN A CELLULAR NETWORK**
- [75] Inventors: **Arogyaswami J. Paulraj**, Stanford;
Robert W. Heath, Jr., Hayward;
Peroor K. Sebastian; David J. Gesbert, both of Mountain View, all of Calif.
- [73] Assignee: **Gigabit Wireless, Inc.**, Mountain View, Calif.
- [21] Appl. No.: **09/364,146**
- [22] Filed: **Jul. 30, 1999**
- [51] **Int. Cl.**⁷ **H04Q 7/28; H04B 7/216; H04B 7/185; H03D 3/22**
- [52] **U.S. Cl.** **370/329; 370/342; 370/341**
- [58] **Field of Search** **370/328, 329, 370/347, 341, 342, 326, 319, 431, 464, 310; 455/13.1, 507, 509, 524, 560; 375/299**

Attorney, Agent, or Firm—Beyer Weaver Thomas & Nguyen

[57] **ABSTRACT**

The present invention provides methods and apparatus for implementing spatial multiplexing in conjunction with the one or more multiple access protocols during the broadcast of information in a wireless network. A wireless cellular network for transmitting subscriber datastream(s) to corresponding ones among a plurality of subscriber units located within the cellular network is disclosed. The wireless cellular network includes base stations and a logic. The base stations each include spatially separate transmitters for transmitting, in response to control signals, selected substreams of each subscriber datastream on an assigned channel of a multiple access protocol. The logic communicates with each of the base stations. The logic assigns an available channel on which to transmit each subscriber datastream. The logic routes at least a substream of each datastream to at least a selected one of the base stations. The logic also generates control signals to configure the at least a selected one of the base stations to transmit the selected substreams to a corresponding one among the plurality of subscriber units on the assigned channel. A subscriber unit for use in a cellular system is also disclosed. The subscriber unit includes: spatially separate receivers, a spatial processor, and a combiner. The spatially separate receivers receive the assigned channel composite signals resulting from the spatially separate transmission of the subscriber downlink datastream(s). The spatial processor is configurable in response to a control signal transmitted by the base station to separate the composite signals into estimated substreams based on information obtained during the transmission of known data patterns from at least one of the base stations. The spatial processor signals the base stations when a change of a spatial transmission configuration is required. The combiner combines the estimated substreams into a corresponding subscriber datastream.

[56] **References Cited**

U.S. PATENT DOCUMENTS

5,345,599	9/1994	Paulraj et al. .	
5,504,936	4/1996	Lee .	
5,592,471	1/1997	Briskman	455/506
5,642,353	6/1997	Roy, III et al.	370/329
5,729,825	3/1998	Kostreski et al. .	
5,732,075	3/1998	Tangemann et al. .	
5,828,658	10/1998	Ottersten et al.	370/329
5,841,971	11/1998	Longginou et al. .	

OTHER PUBLICATIONS

Arogyaswami J. Paulraj and Constantinos B. Papadias "Space-Time Processing for Wireless Communications", IEEE Signal Processing Magazine, Nov. 1997.

Primary Examiner—Chi H. Pham
Assistant Examiner—Brenda H. Pham

47 Claims, 31 Drawing Sheets

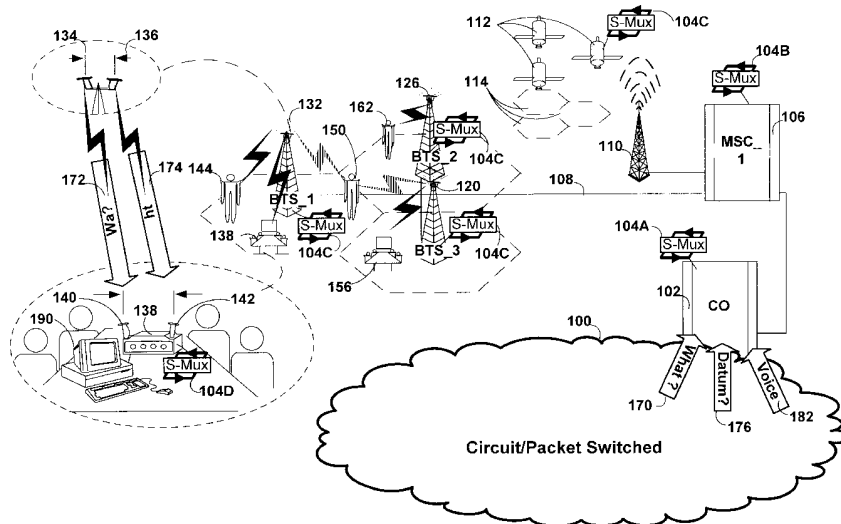

SPATIAL MULTIPLEX

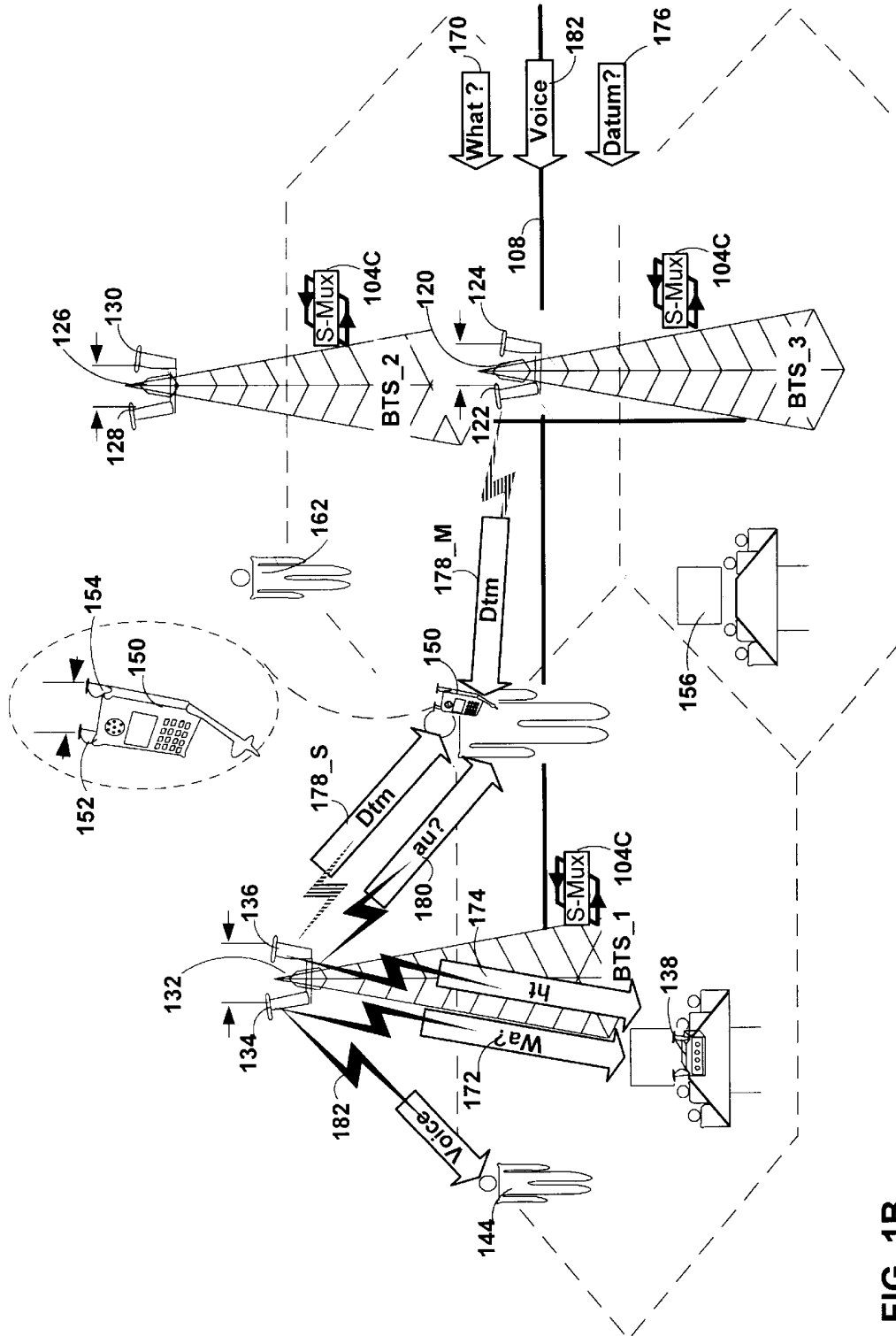

FIG. 1B

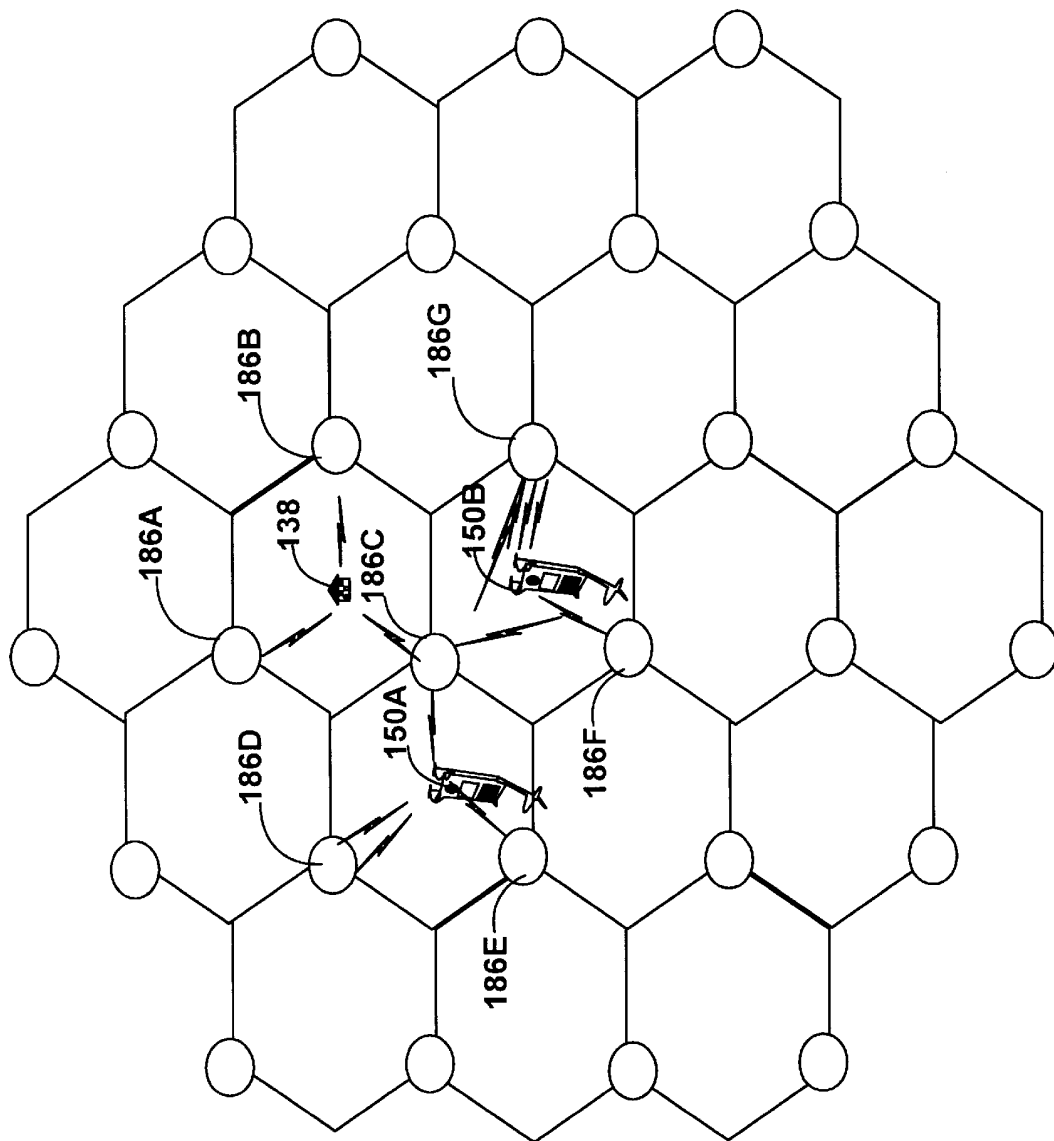

FIG.1C

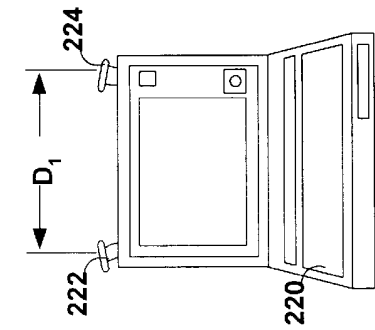

FIG. 2F

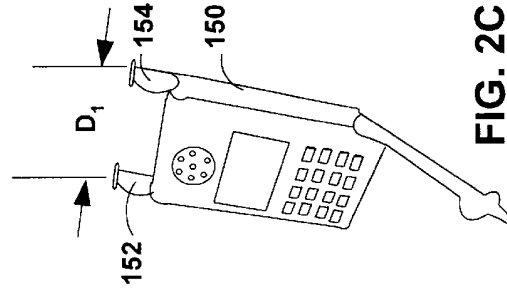

FIG. 2C

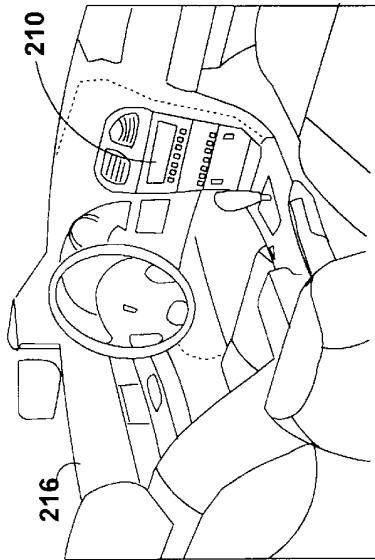

FIG. 2E

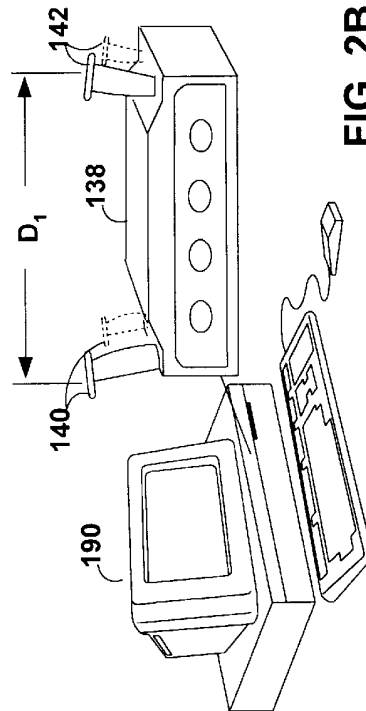

FIG. 2B

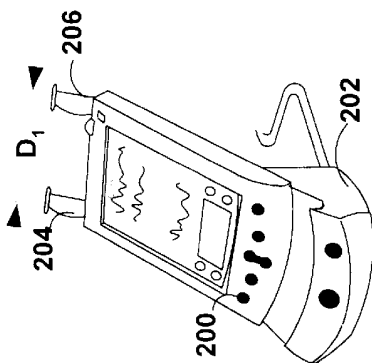

FIG. 2D

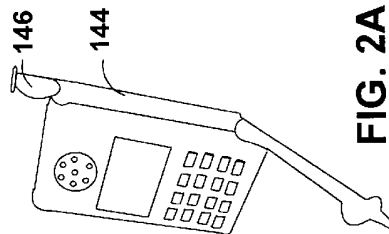

FIG. 2A

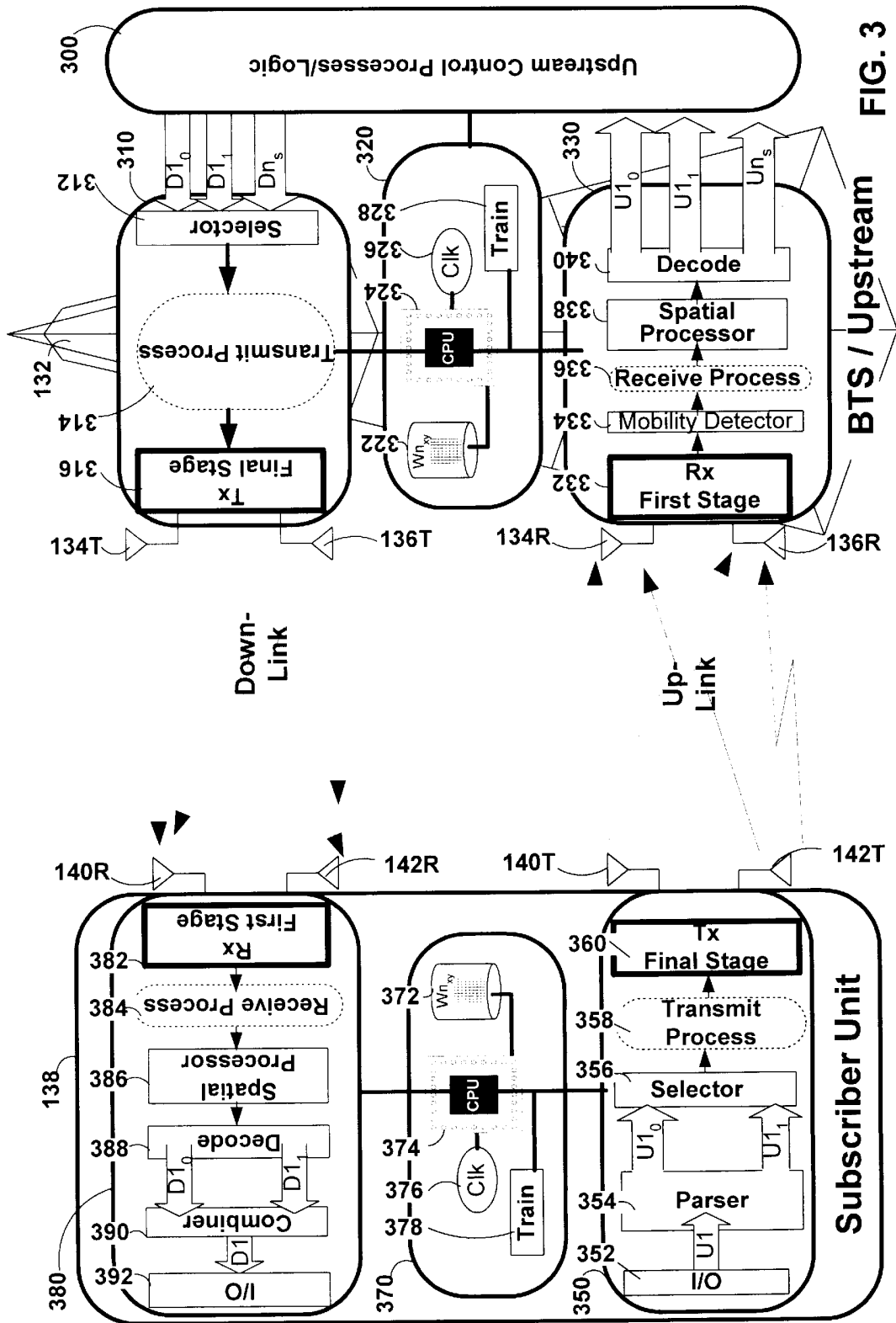

FIG. 3

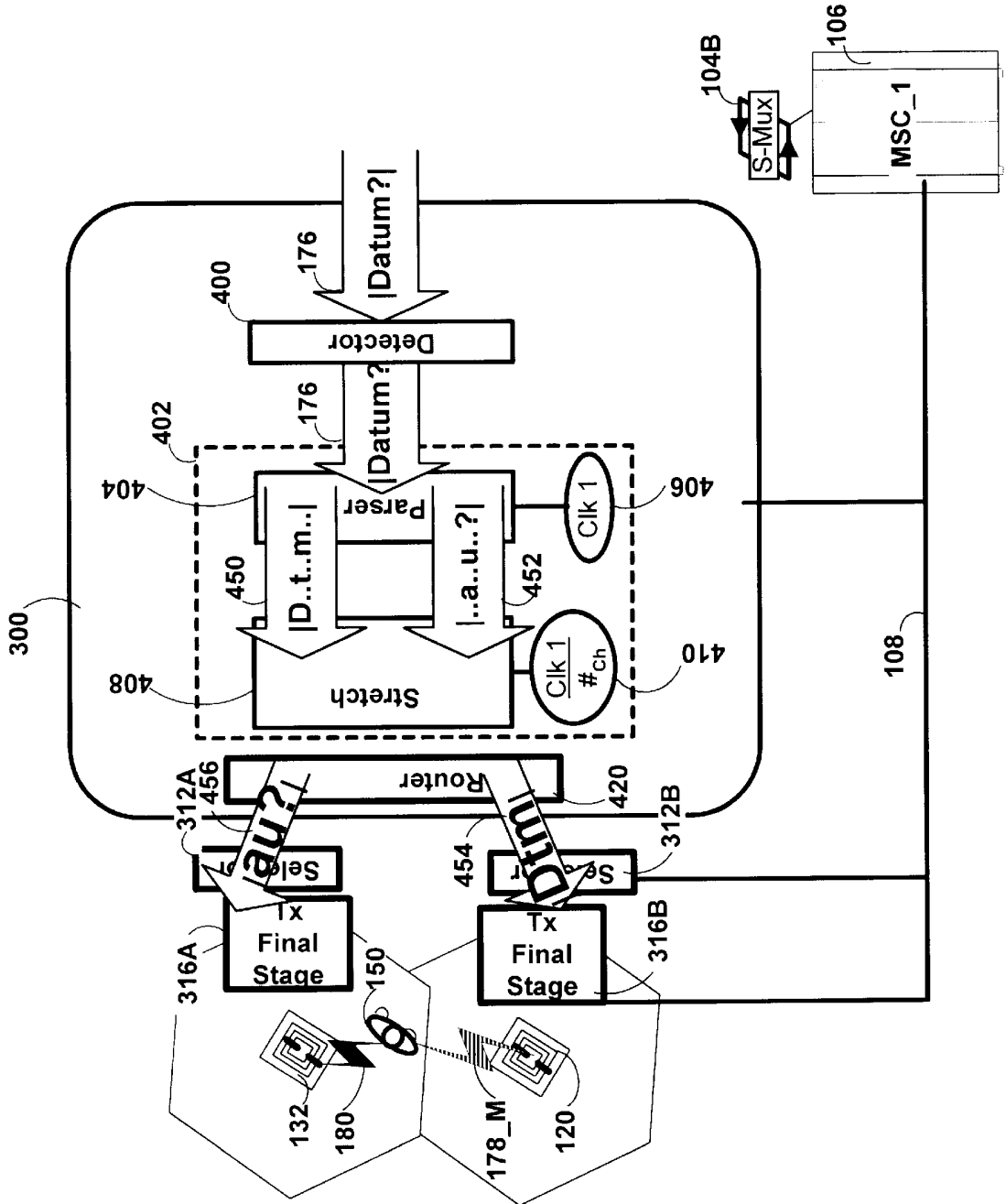

FIG. 4B

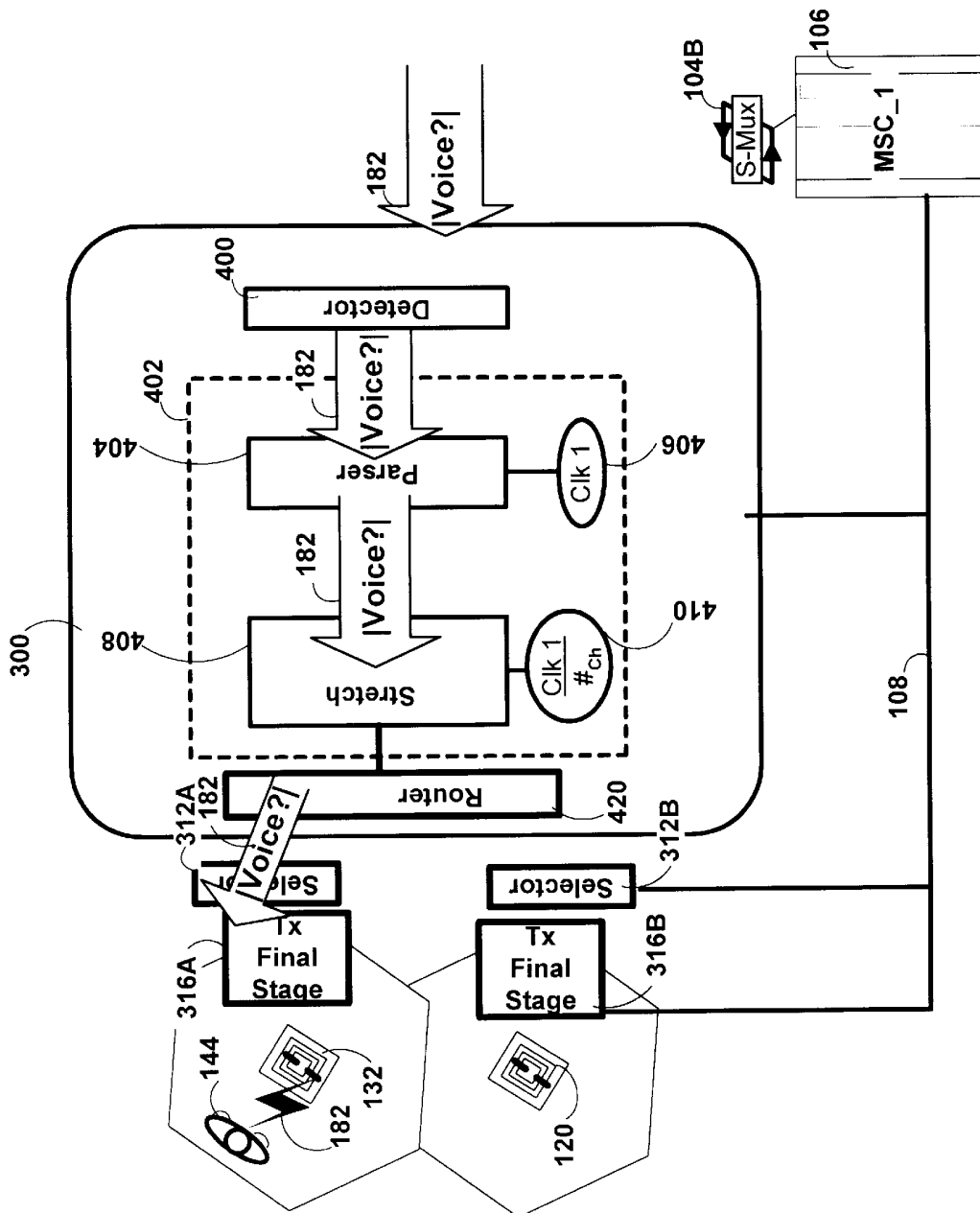

FIG. 4C

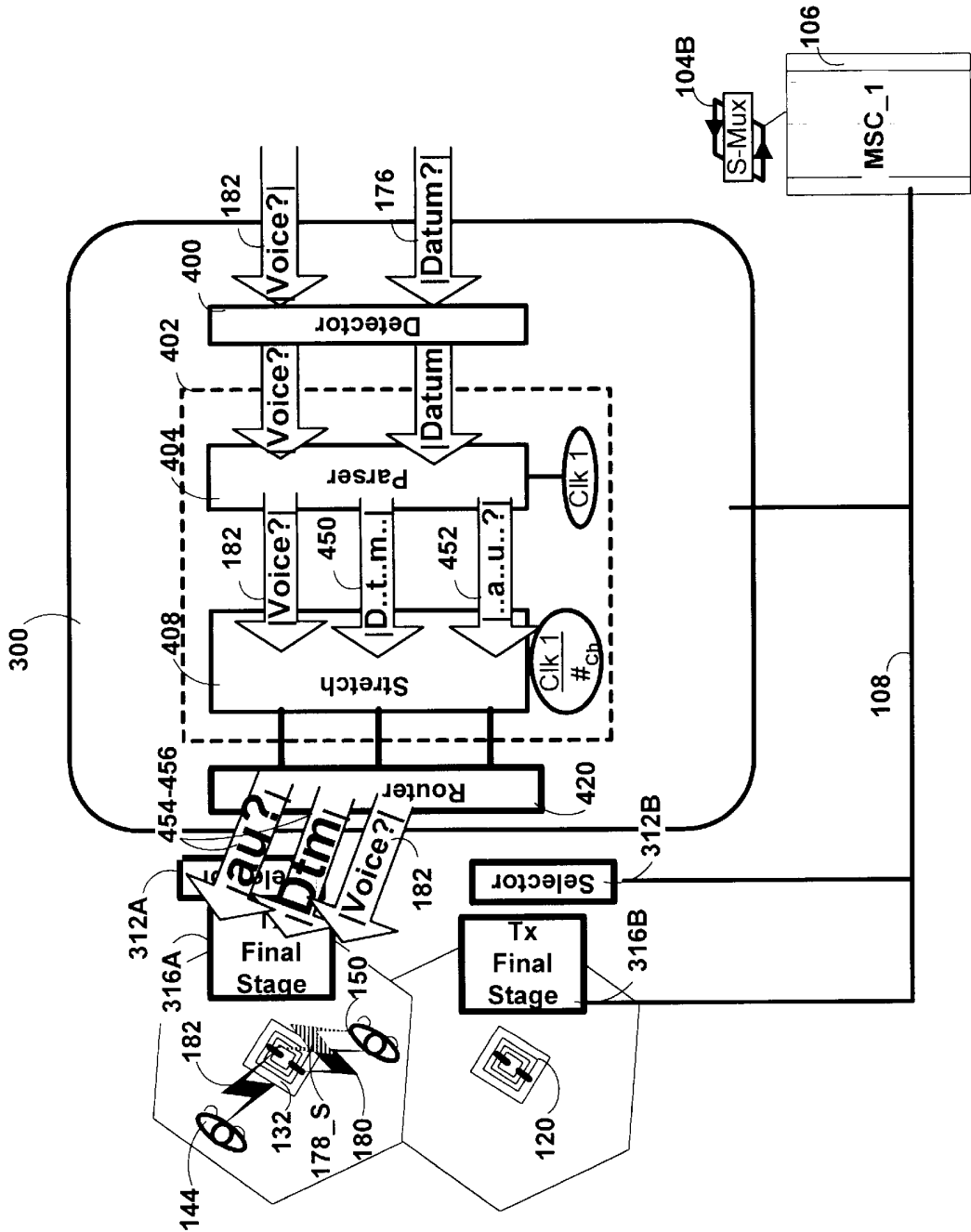

FIG. 4D

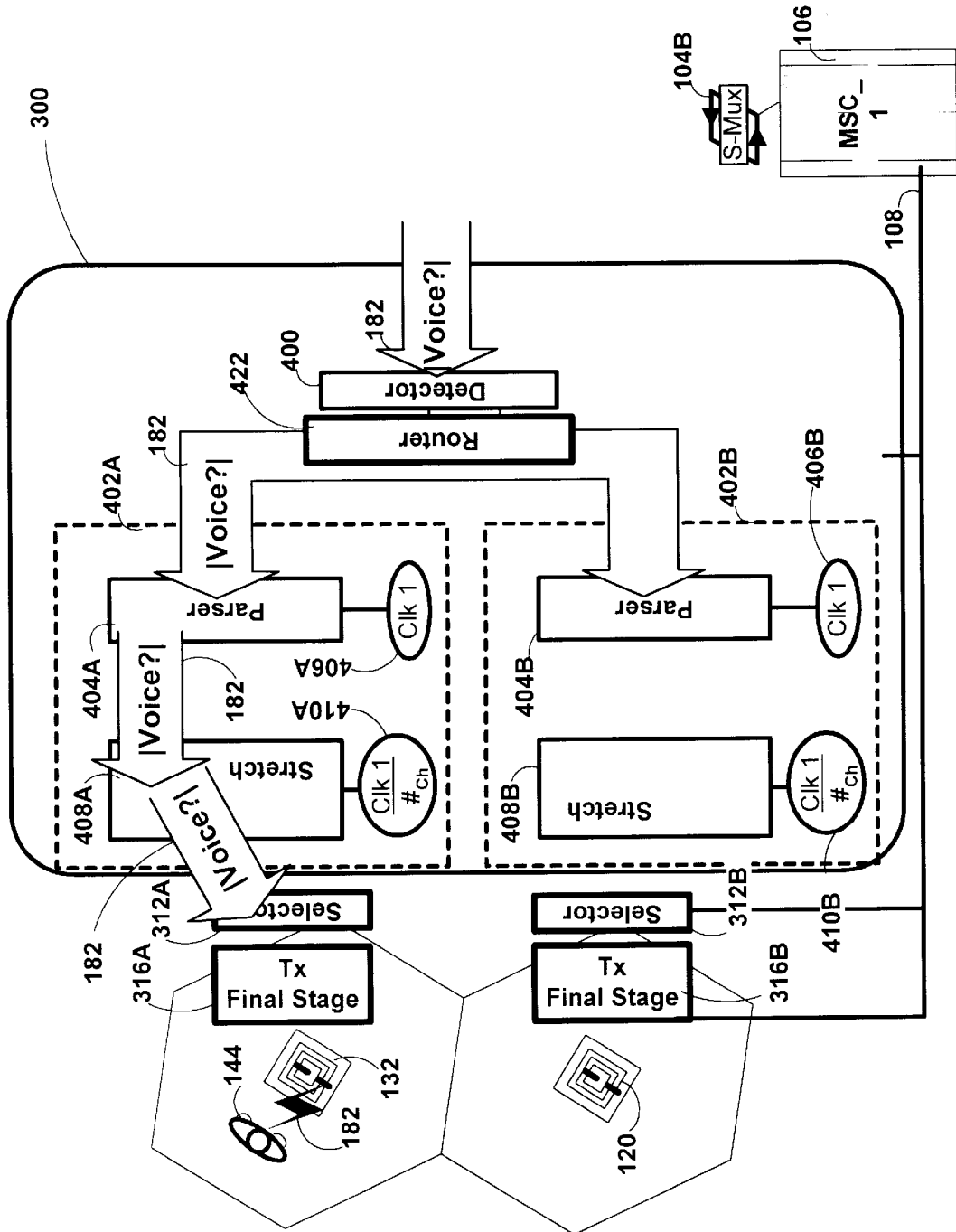

FIG. 4H

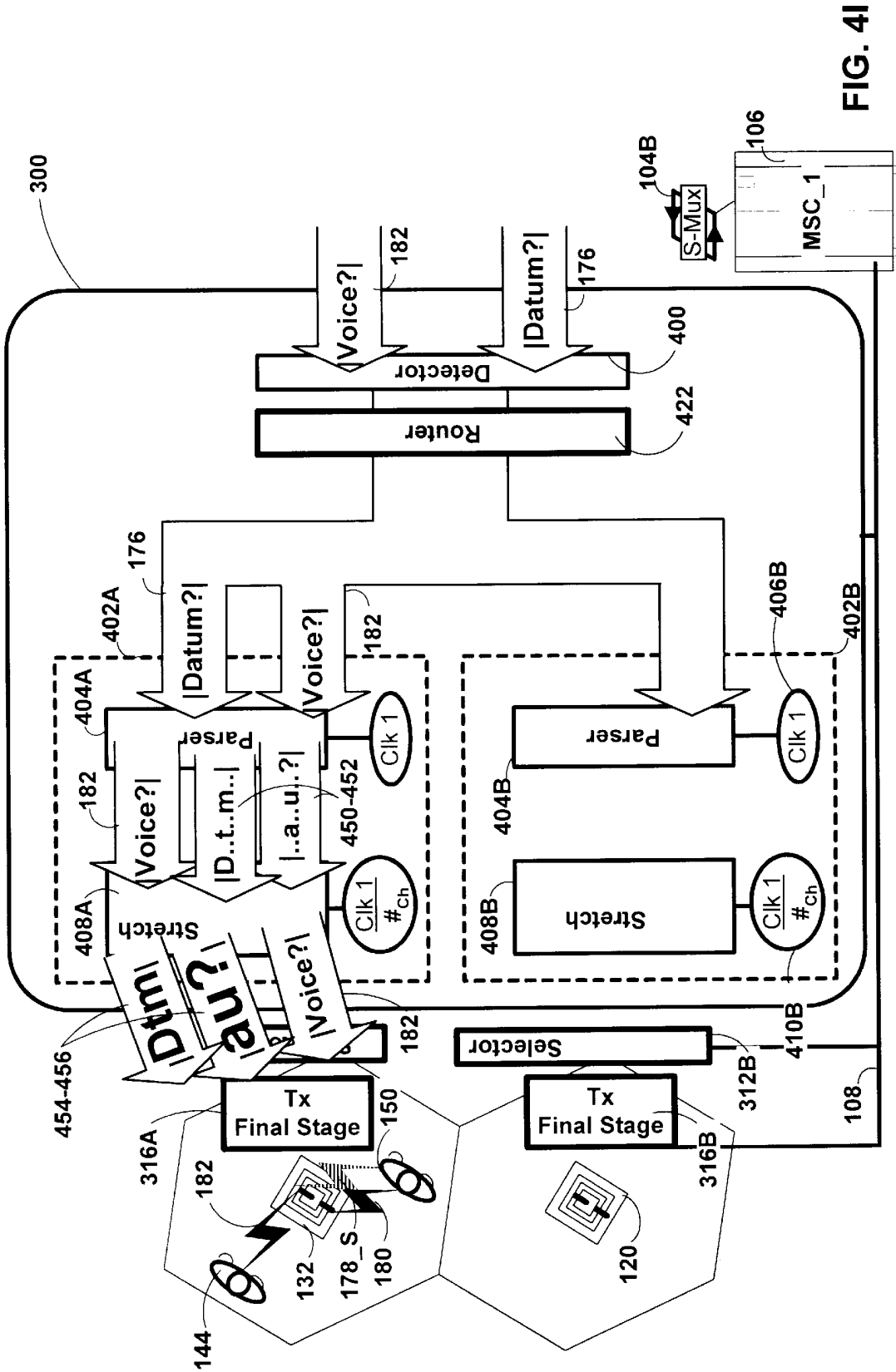

FIG. 4I

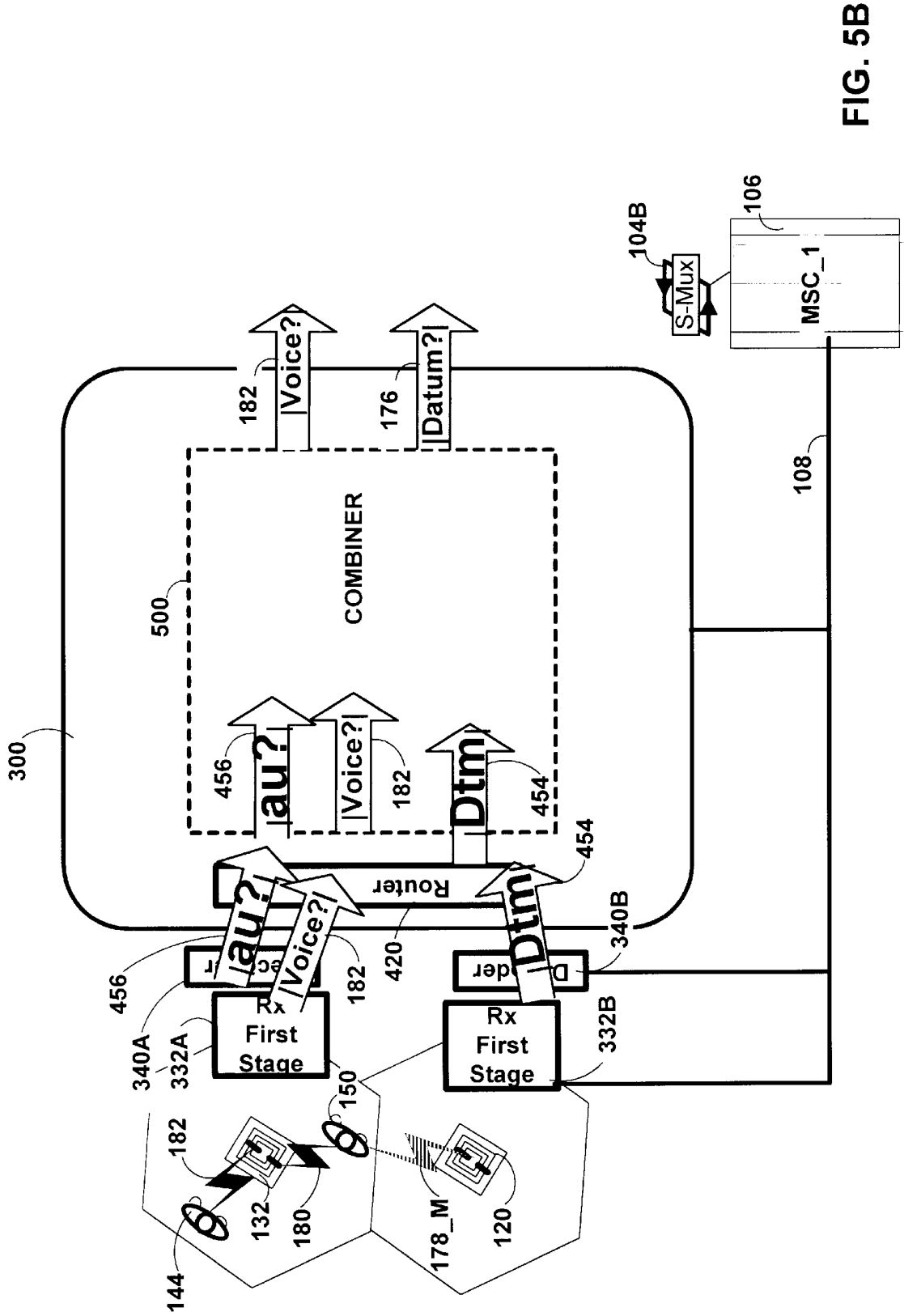
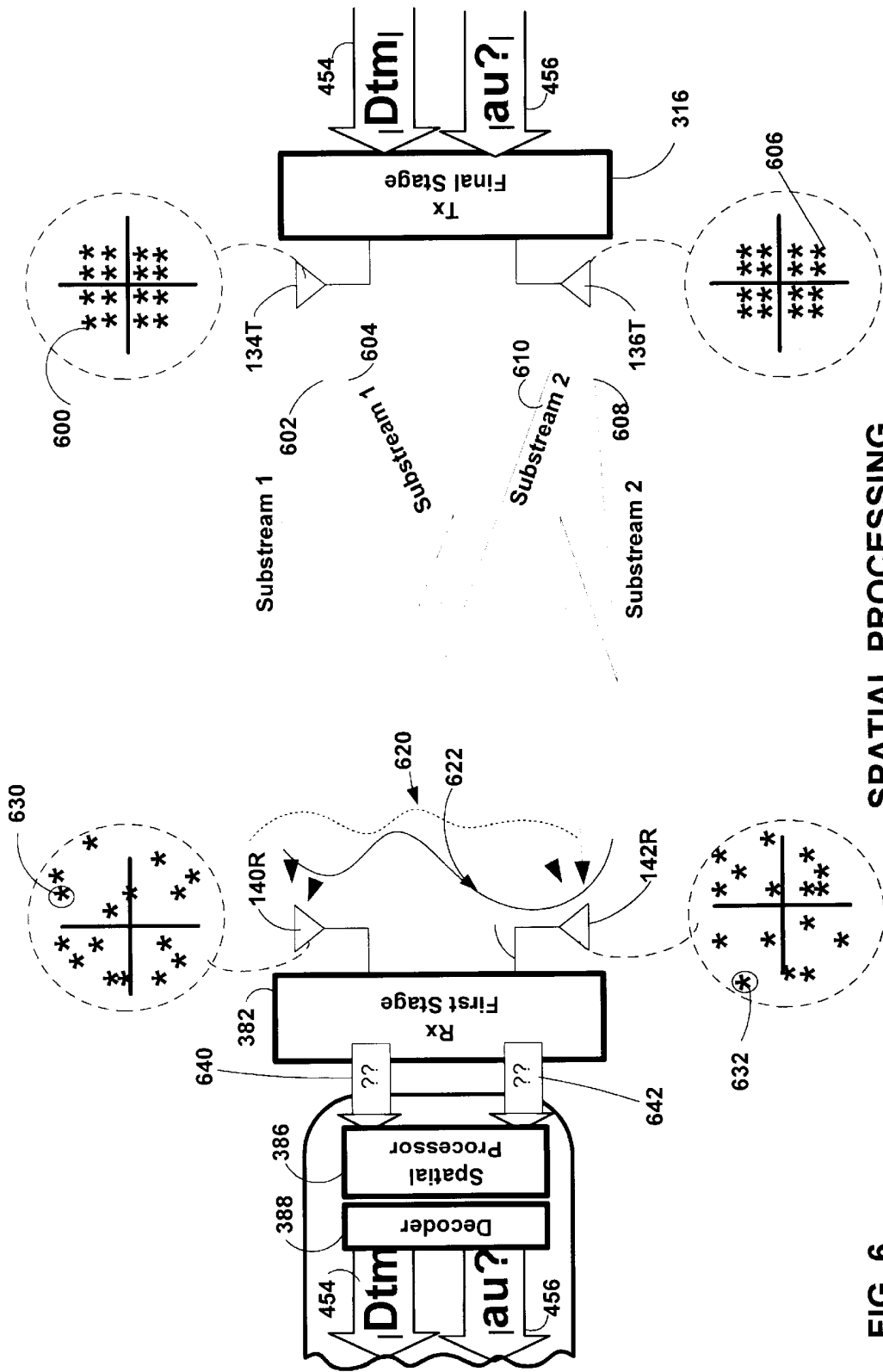
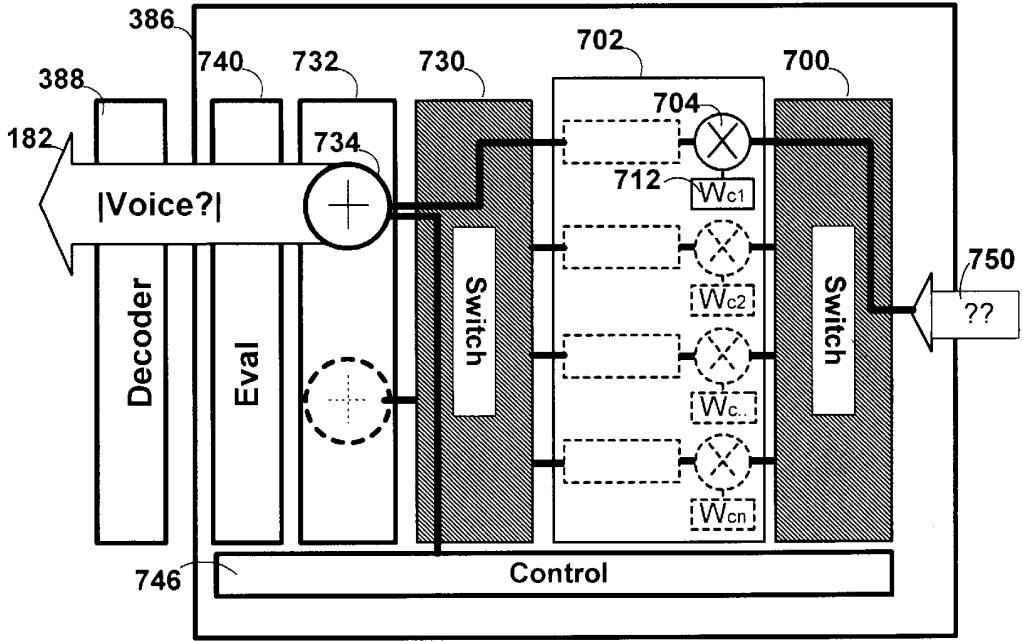

FIG. 5B



SPATIAL PROCESSING

FIG. 6



Spatial Processor FIG. 7A

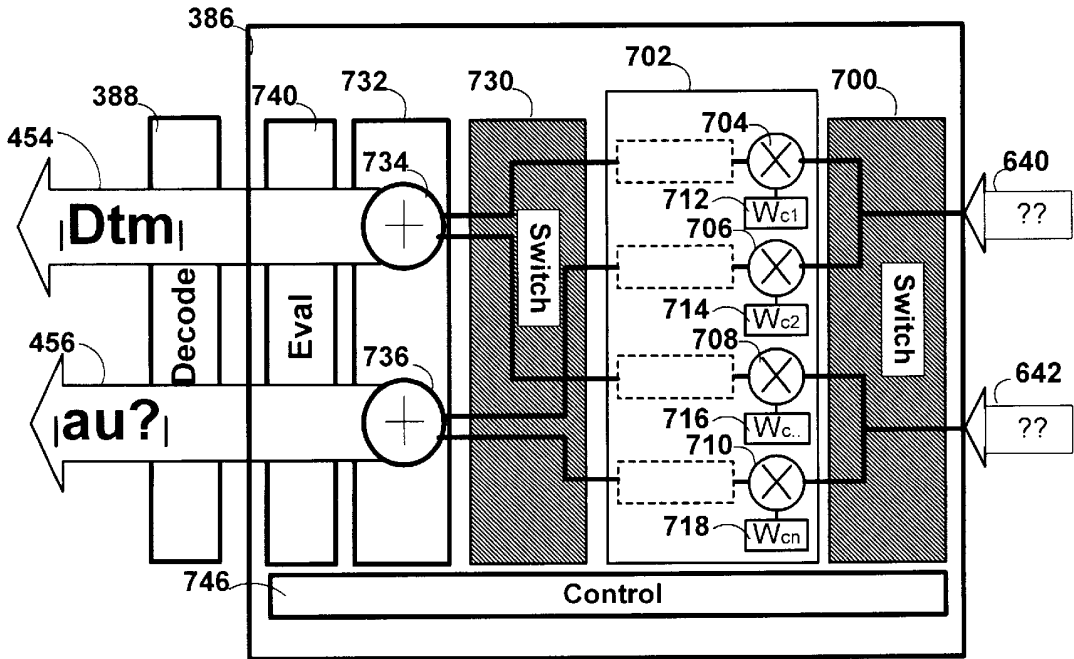

Spatial Processor

FIG. 7B

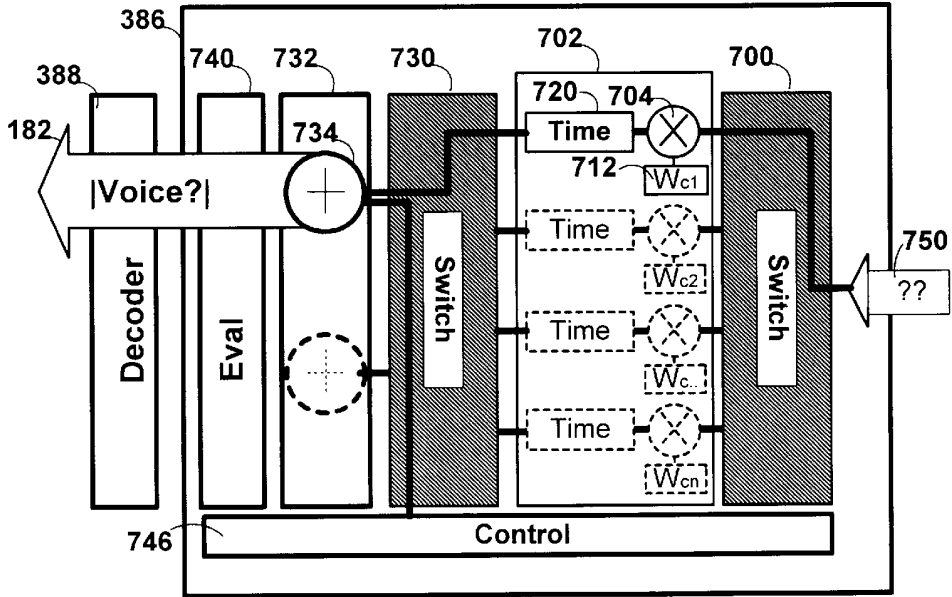

Space-Time Processor FIG. 7C

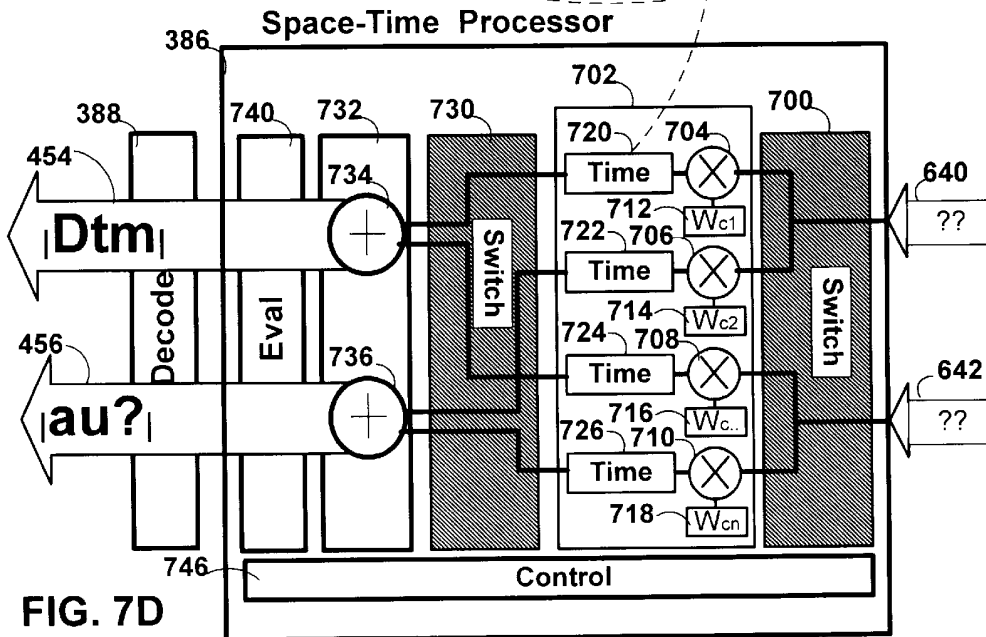
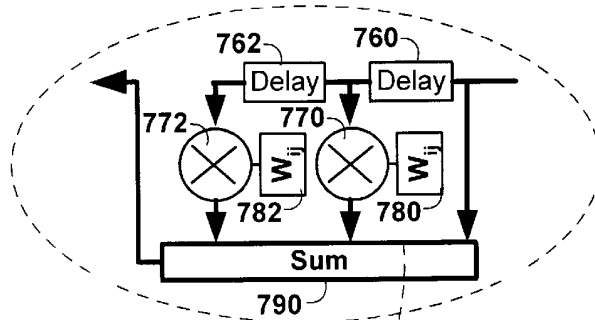

FIG. 7D

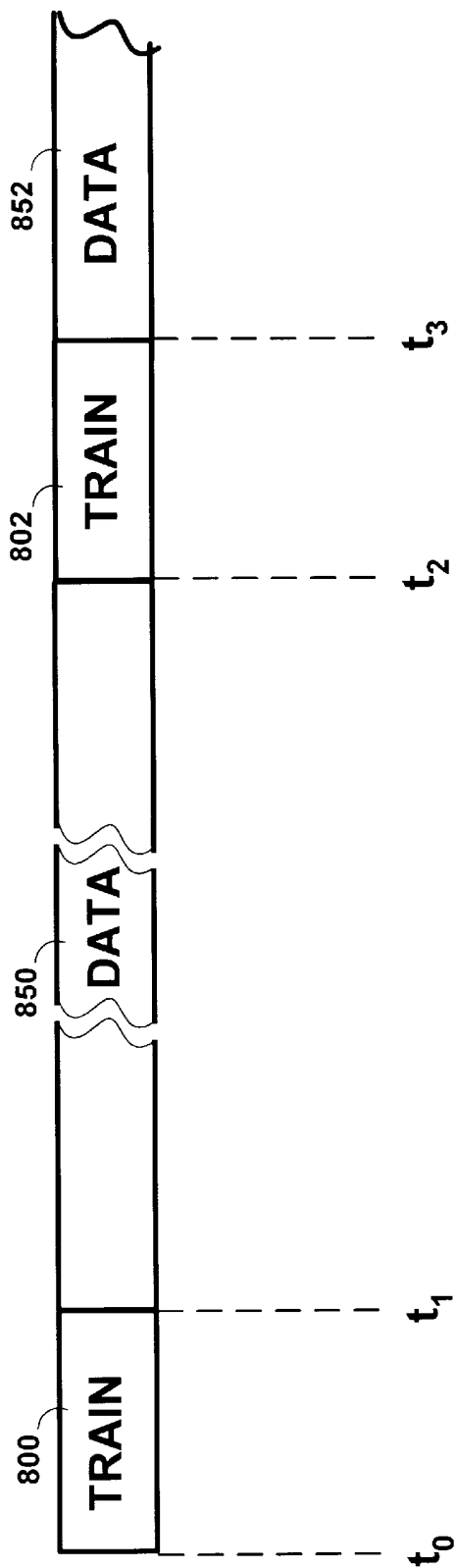

FIG. 8

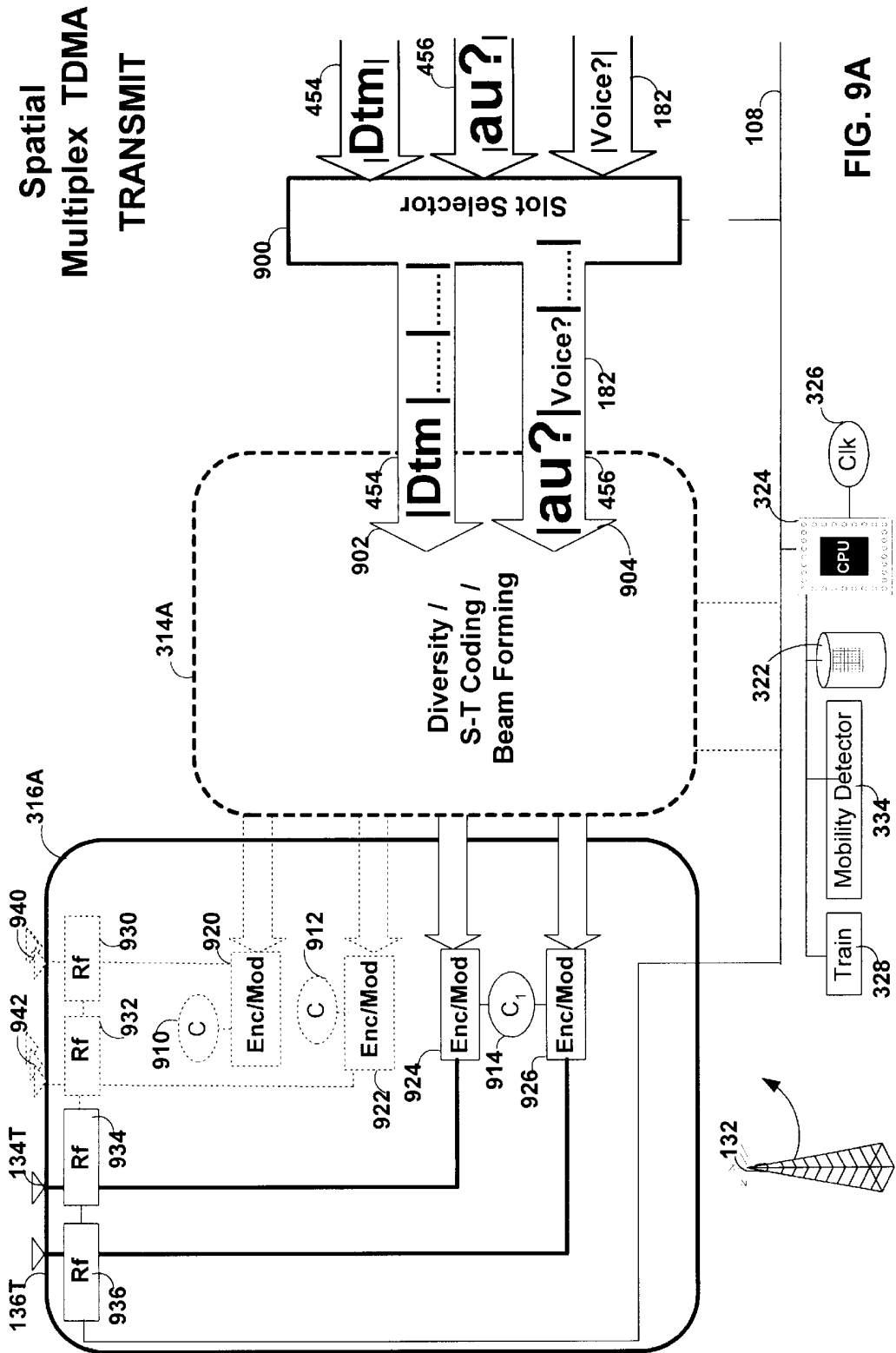

FIG. 9A

**Spatial Multiplex
TDMA
RECEIVE**

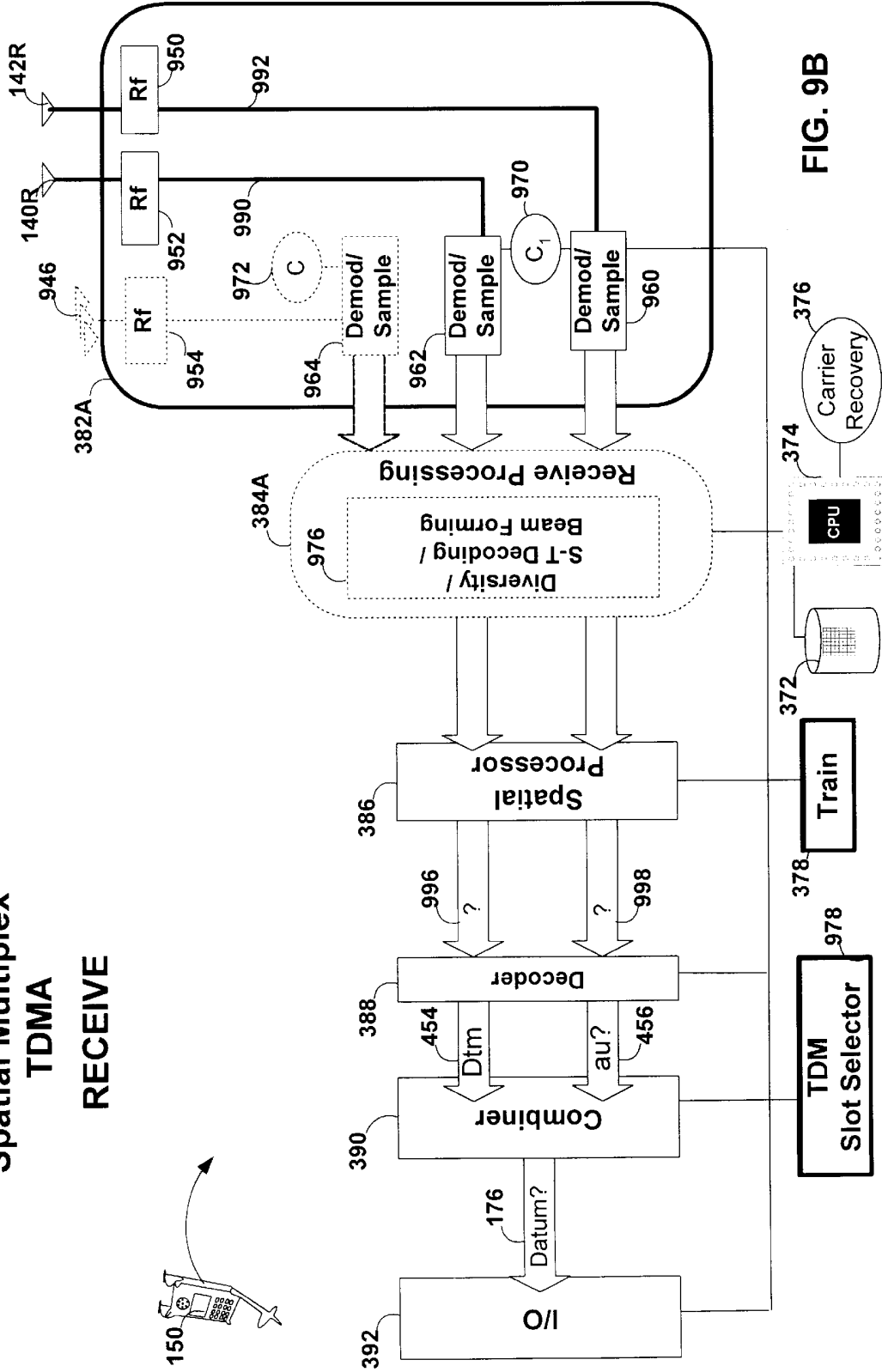

FIG. 9B

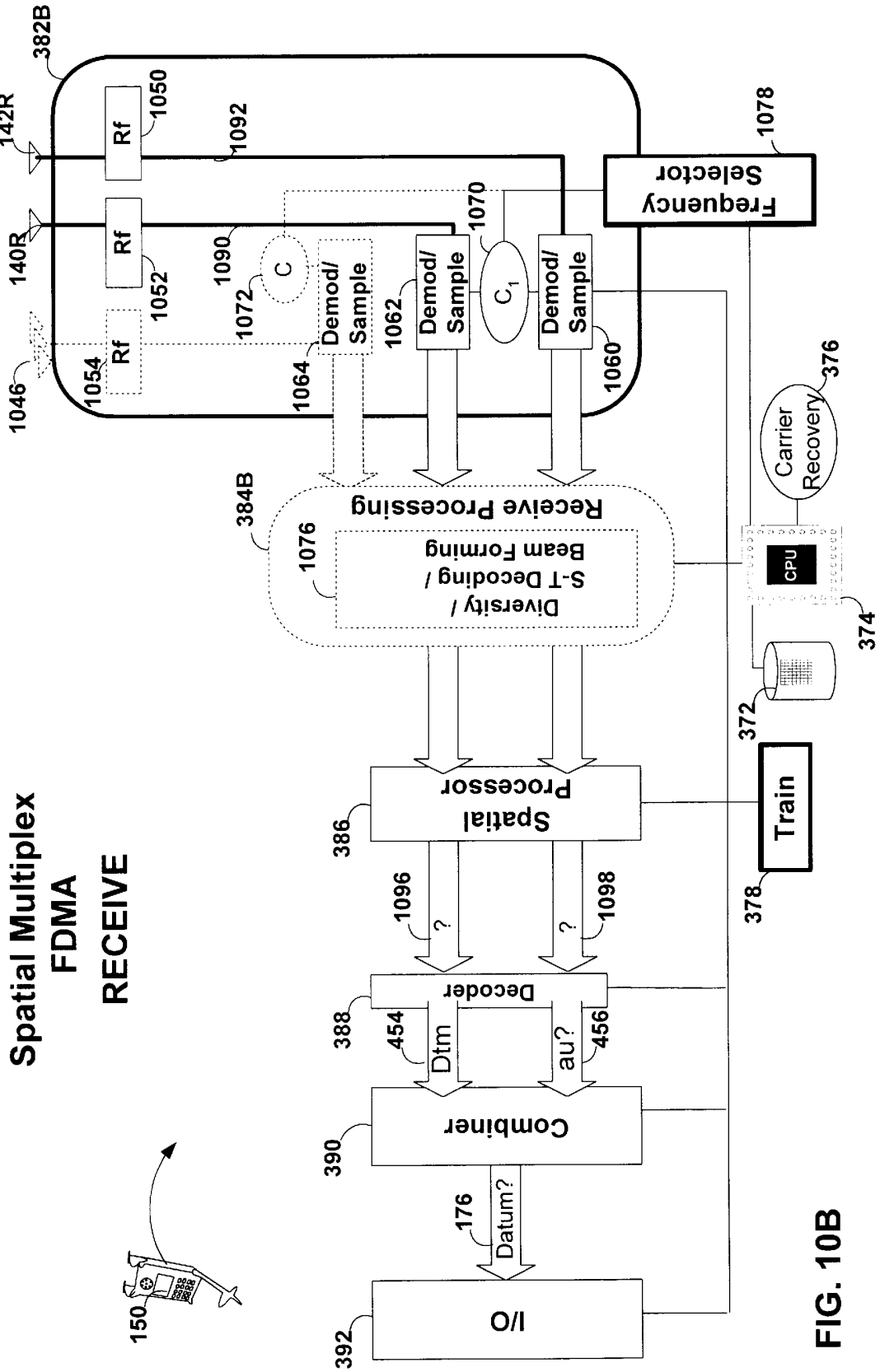

FIG. 10B

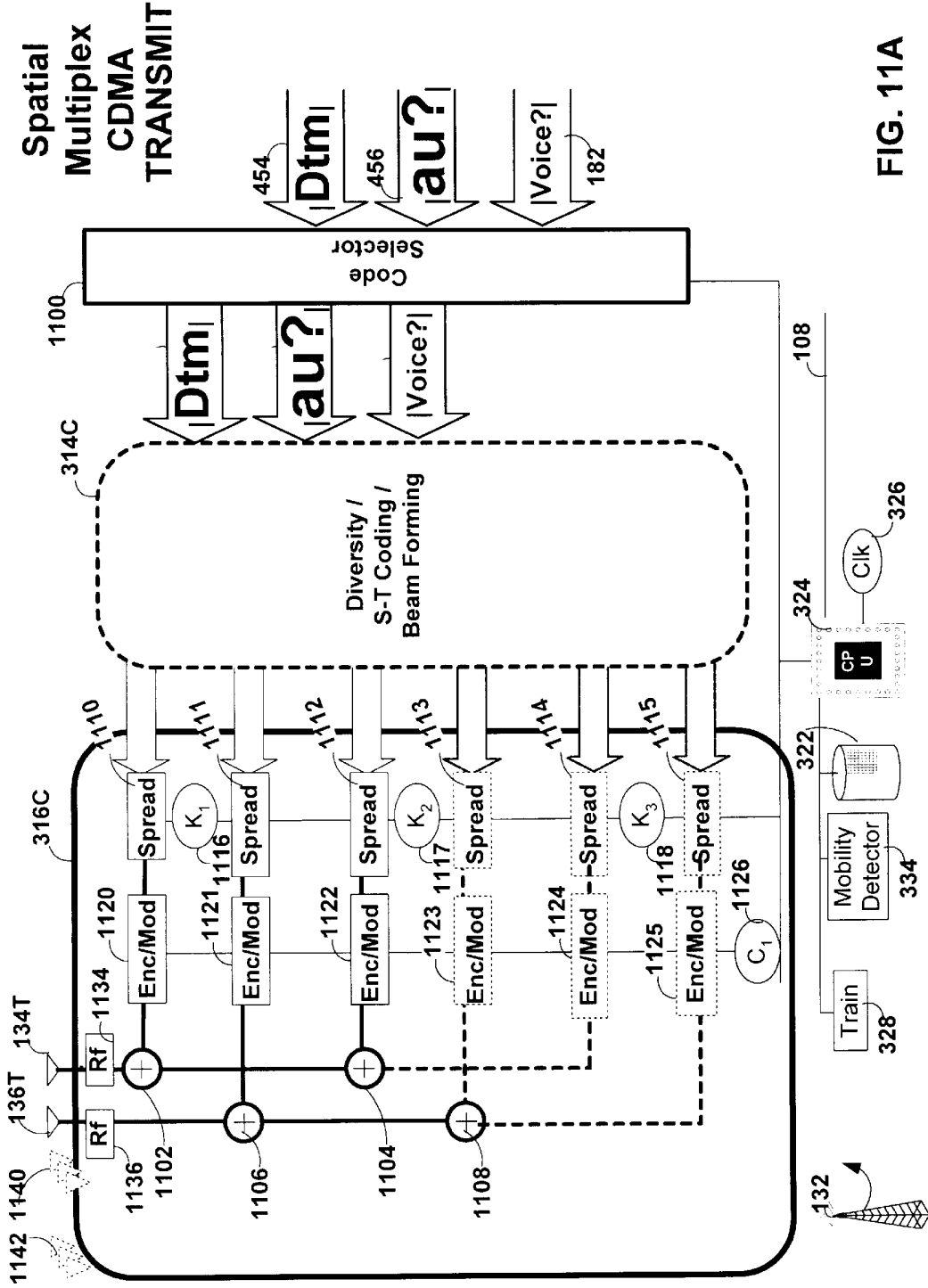
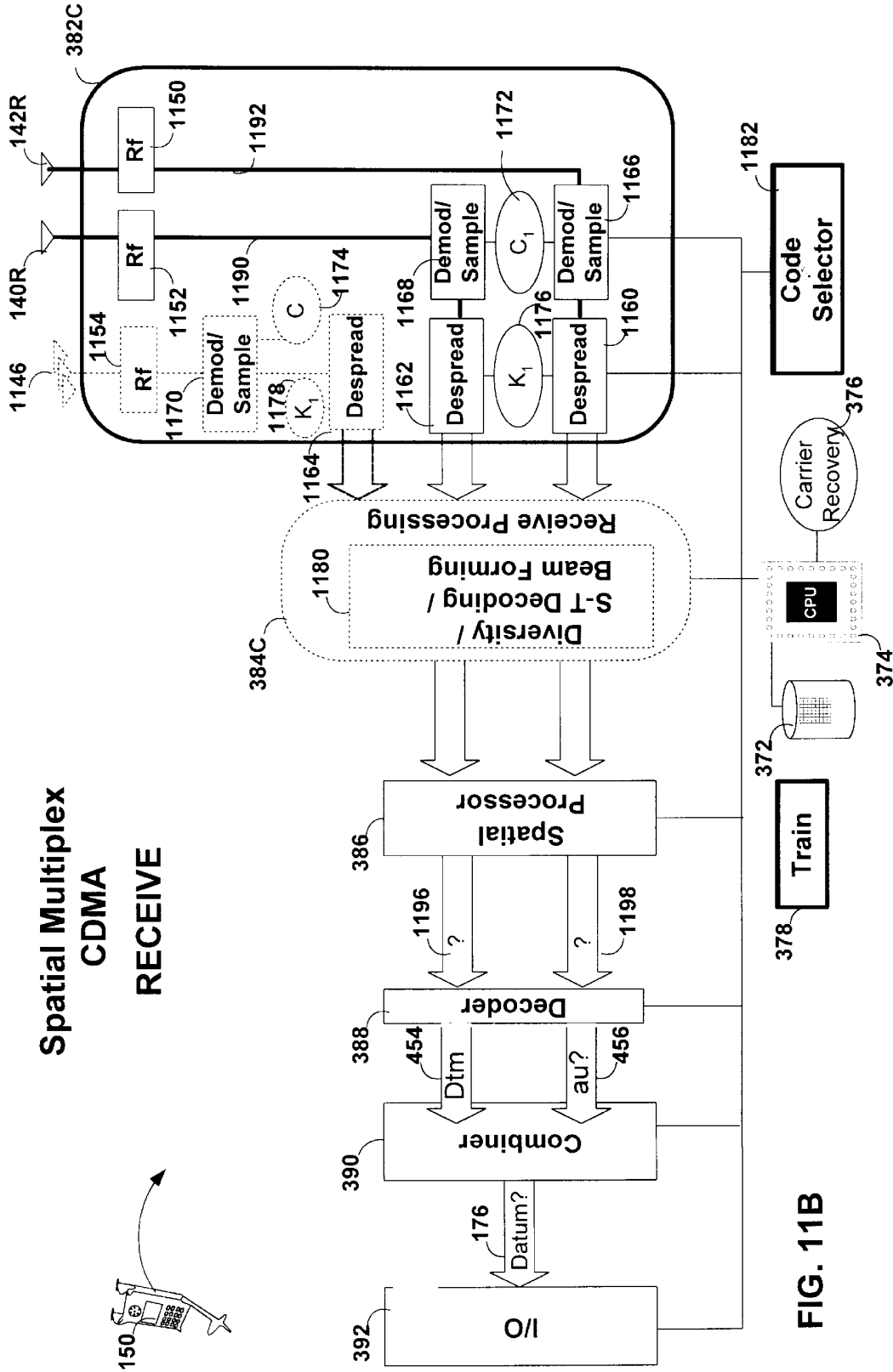

FIG. 11A



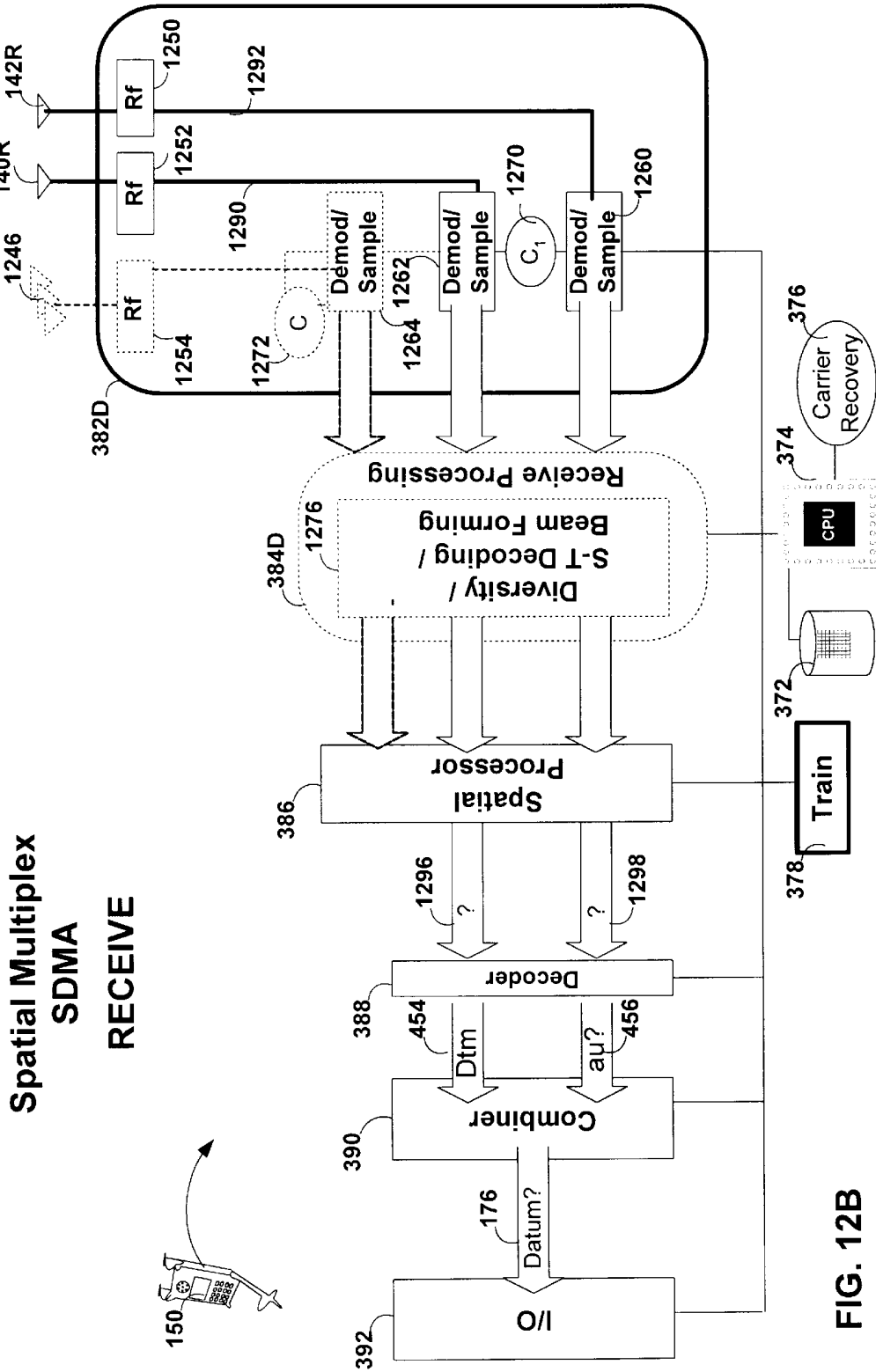

FIG. 12B

FIG. 13A

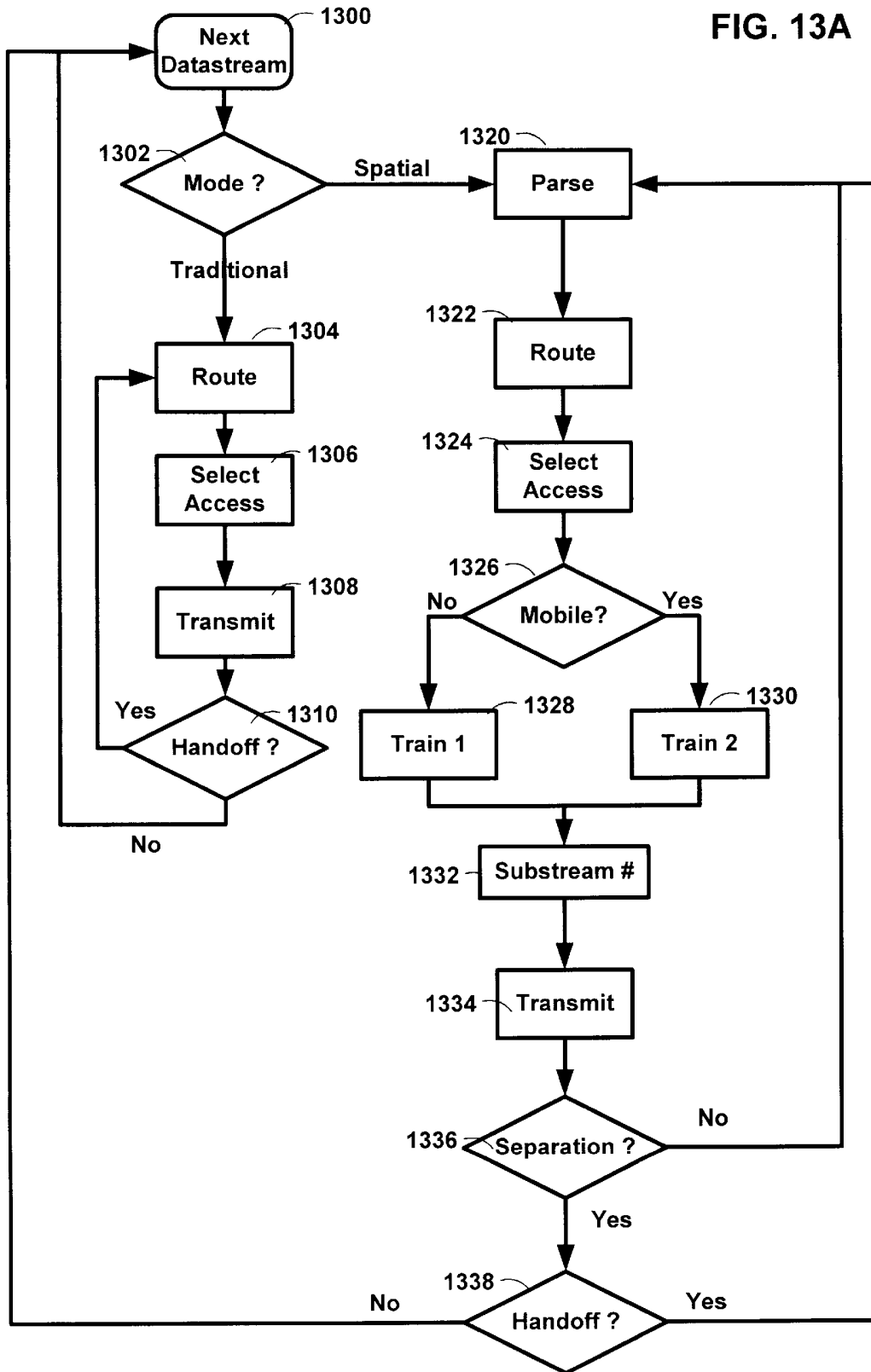
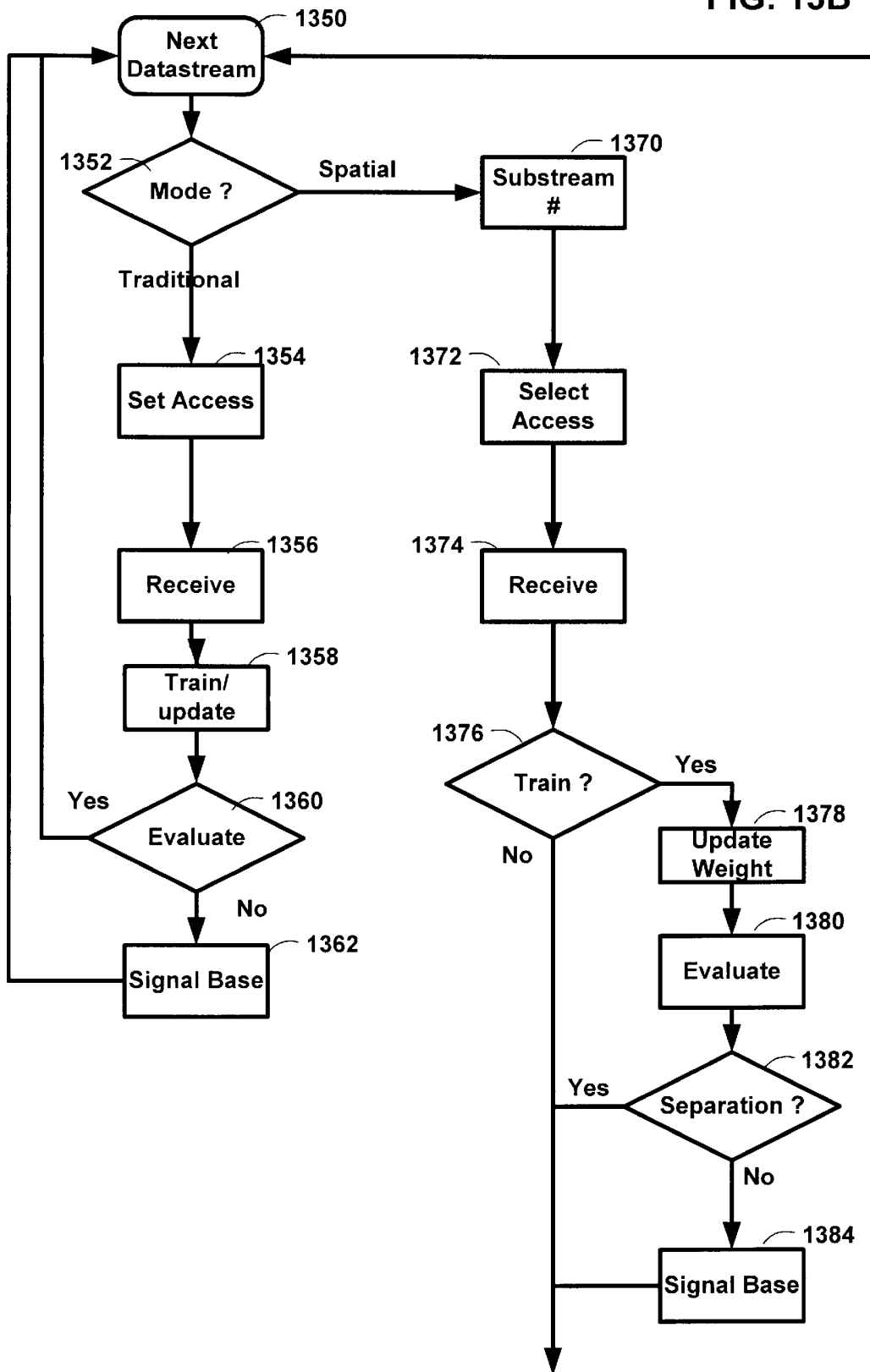

FIG. 13B



SPATIAL MULTIPLEXING IN A CELLULAR NETWORK

BACKGROUND OF THE INVENTION

Copyright Authorization

A portion of the disclosure of this patent document contains material which is subject to copyright protection. The copyright owner has no objection to the facsimile reproduction by any one of the patent disclosure, as it appears in the U.S. Patent and Trademark Office patent files or records, but otherwise reserves all copyright rights whatsoever.

1. Field of Invention

The field of the present invention relates in general to the field of wireless broadcast of information using one or more multiple access protocols and in particular to methods and apparatus for implementing spatial multiplexing in conjunction with the one or more multiple access protocols during the broadcast of information.

2. Description of the Related Art

In wireless broadcast systems, information generated by a source is transmitted by wireless means to a plurality of receivers within a particular service area. The transmission of such information requires a finite amount of bandwidth, and in current state of the art transmission of information from different sources, must occur in different channels.

Since there are quite a few services (e.g. television, FM radio, private and public mobile communications, etc.) competing for a finite amount of available spectrum, the amount of spectrum which can be allocated to each channel is severely limited. Innovative means for using the available spectrum more efficiently are of great value. In current state of the art systems, such as cellular telephone or broadcast television, a suitably modulated signal is transmitted from a single base station centrally located in the service area or cell and propagated to receiving stations in the service area surrounding the transmitter. The information transmission rate achievable by such broadcast transmission is constrained by the allocated bandwidth. Due to attenuations suffered by signals in wireless propagation, the same frequency channel can be re-used in a different geographical service area or cell. Allowable interference levels determine the minimum separation between base stations using the same channels. What is needed is a way to improve data transfer speed in the multiple access environments currently utilized for wireless communications within the constraints of available bandwidth.

SUMMARY OF THE INVENTION

The present invention provides methods and apparatus for implementing spatial multiplexing in conjunction with the one or more multiple access protocols during the broadcast of information in a wireless network.

In an embodiment of the invention, a wireless cellular network for transmitting subscriber datastream(s) to corresponding ones among a plurality of subscriber units located within the cellular network is disclosed. The wireless cellular network includes base stations and a logic. The base stations each include spatially separate transmitters for transmitting in response to control signals and selected substreams of each subscriber datastream on an assigned channel of a multiple access protocol. The logic communicates with each of the base stations. The logic assigns an available channel on which to transmit each subscriber

datastream. The logic routes at least a substream of each datastream to at least a selected one of the base stations. The logic also generates control signals to configure at least a selected one of the base stations to transmit the selected substreams to a corresponding one among the plurality of subscriber units on the assigned channel.

In an embodiment of the invention, a subscriber unit for use in a cellular system with base stations, each including spatially separate transmitters for transmitting selected substreams of at least one of a plurality of subscriber downlink datastream(s) on an assigned channel of a multiple access protocol, is disclosed. The subscriber unit includes: spatially separate receivers, a spatial processor, and a combiner. The spatially separate receivers receive the assigned channel composite signals resulting from the spatially separate transmission of the subscriber downlink datastream(s). The spatial processor is configurable in response to a control signal transmitted by the base station to separate the composite signals into estimated substreams based on information obtained during the transmission of known data patterns from at least one of the base stations or by using blind training techniques. The spatial processor signals the base stations when a change of a spatial transmission configuration is required in order to resolve the composite signals into estimated downlink datastream(s). The combiner combines the estimated substreams into a corresponding subscriber datastream.

In another embodiment of the invention, a wireless cellular network for transmitting subscriber downlink datastream(s) from a first network to subscribers located within the wireless cellular network is disclosed. The wireless cellular network includes: base stations, subscriber units and a logic. The base stations are each configured for spatially separate transmission of selected substreams of each subscriber downlink datastream on an assigned channel of a multiple access protocol. The subscriber units are each configured for spatially separate reception on the assigned channel of the selected substreams, for combining the substreams into the corresponding subscriber datastream and for initiating a change signal to at least one of the base stations when a change of a spatial transmission configuration is required in order to separate the selected substreams. The logic communicates with each of the base stations and to the first network. The logic is configured to route at least a substream of each subscriber downlink datastream to at least a selected one of the base stations and further configured to vary the routing between a single base station and multiple base stations to vary a spatial transmission configuration of the selected substreams.

In another embodiment of the invention, a wireless cellular network for receiving subscriber datastreams at corresponding ones among a plurality of base stations located within the cellular network is disclosed. The wireless cellular network includes: subscriber units and logic. The subscriber units each include spatially separate transmitters for transmitting, in response to control signals, selected substreams of each subscriber datastream on an assigned channel of a multiple access protocol. The logic communicates with each of the base stations. The logic generates control signals to configure selected ones of the base stations to receive composite signals resulting from the spatially separate transmission of the selected substreams from a corresponding one among the plurality of subscriber units on the assigned channel. The logic also converts the composite signals into estimate substreams and combines the estimated substreams of each subscriber datastream into each subscriber datastream.

In another embodiment of the invention, a wireless cellular network for transmitting subscriber downlink datastream(s) from a first network to subscribers located within the wireless cellular network is disclosed. The wireless cellular network includes base stations and logic. The base stations include at least one transmitter, for transmitting in response to control signals selected substreams of each subscriber datastream on an assigned channel of a multiple access protocol. The logic communicates with each of the base stations. The logic for assigns an available channel on which to transmit each subscriber datastream. The logic routes at least a substream of each datastream to at least a selected one of the base stations. The logic further generates control signals to configure the at least a selected one of the base stations to transmit the selected substreams to a corresponding one among the plurality of subscriber units on the assigned channel.

In an embodiment of the invention, a method for transmitting subscriber downlink datastream(s) from base stations to corresponding ones among a plurality of subscriber units is disclosed. The method includes the acts of:

- routing at least a substream of each subscriber downlink datastream to selected one of the base stations;
- transmitting the at least a substream of each subscriber downlink datastream from the selected one of the base stations on an assigned channel of a multiple access protocol; and
- re-routing at least a substream of each subscriber downlink datastream between a single base station and multiple base stations responsive to a determination that a change of a spatial transmission configuration of the at least a substream of each subscriber downlink datastream signal is required.

In another embodiment of the invention, a method for receiving subscriber downlink datastream(s) transmitted from a plurality of spatially separate transmitters is disclosed. The method includes the acts of:

- receiving signals generated from at least one of the plurality of spatially separate transmitters;
- determining a number of substreams to be derived from the signals;
- separating the signals into the number of substreams determined in said act of determining; and
- combining the substreams into a corresponding subscriber downlink datastream.

In another embodiment of the invention, a wireless cellular network for transmitting subscriber datastream(s) to corresponding ones among a plurality of subscriber units located within the cellular network is disclosed. The wireless cellular network includes:

- means for routing at least a substream of each subscriber downlink datastream to selected ones of the base stations;
- means for transmitting the at least a substream of each subscriber downlink datastream from the selected ones of the base stations on an assigned channel of a multiple access protocol; and
- means for re-routing the at least a substream of each subscriber downlink datastream between a single base station and multiple base stations responsive to a signal from a corresponding one of the subscriber units requesting a change of spatial transmission configuration.

In another embodiment of the invention, a subscriber unit for use in a cellular system with base stations each including

spatially separate transmitters for transmitting selected substreams of at least one of a plurality of subscriber downlink datastream(s) on an assigned channel of a multiple access protocol is disclosed. The subscriber unit includes:

- means for receiving signals generated from at least one of the plurality of spatially separate transmitters;
- means for determining a number of substreams to be derived from the signals;
- means for separating the signals into the number of substreams determined in said act of determining;
- means for combining the substreams into a corresponding subscriber downlink datastream; and
- means for signaling the base when a change of a spatial transmission configuration is required in order to resolve the composite signals into estimated substreams.

BRIEF DESCRIPTION OF THE DRAWINGS

These and other features and advantages of the present invention will become more apparent to those skilled in the art from the following detailed description in conjunction with the appended drawings in which:

FIG. 1 shows a wireless cellular network incorporating spatial multiplexing and multiple access according to the current invention.

FIG. 1B is a detailed view of selected cells within the cellular network shown in FIG. 1A.

FIG. 1C shows a cell architecture that provides overlapping regions suitable for multi-base spatial multiplexing.

FIGS. 2A–F show alternate embodiments for the subscriber units utilized in the wireless cellular network shown in FIGS. 1A–B.

FIG. 3 shows a detailed hardware block diagram of a single base station and subscriber unit for use in the wireless cellular network shown in FIGS. 1A–B.

FIGS. 4A–J show detailed hardware block diagrams of the multiple access hardware for controlling the transmission of subscriber datastream(s) from one or more of the base stations within the wireless network.

FIGS. 5A–B show detailed hardware block diagrams of the hardware associated with the receipt of multiple subscriber datastream(s) at the base stations of the wireless network of the current invention.

FIG. 6 shows a detailed view of the signals and the symbols associated with the transmission and receipt of spatially multiplexed signals according to an embodiment of the current invention.

FIGS. 7A–B show detailed hardware block diagrams of the configurable spatial processor associated with the receiver circuitry receiver, according to an embodiment of the current invention.

FIGS. 7A–D show detailed hardware block diagrams of a configurable space and space-time processor associated with the configurable spatial receiver according to an embodiment of the current invention.

FIG. 8 shows in-band training and data signals for calibrating the spatially configurable receiver during the transmission of spatially multiplexed data, according to an embodiment of the current invention.

FIGS. 9A–B are respectively detailed hardware block diagrams of a spatially multiplexed transmitter and receiver implementing a time-division multiple access protocol (TDMA), according to an embodiment of the current invention.

FIGS. 10A–B are respectively detailed hardware block diagrams of a spatially multiplexed transmitter and receiver implementing a frequency-division multiple access protocol (FDMA), according to an embodiment of the current invention.

FIGS. 11A–B are respectively detailed hardware block diagrams of a spatially multiplexed transmitter and receiver implementing a code-division multiple access protocol (CDMA), according to an embodiment of the current invention.

FIGS. 12A–B are respectively detailed hardware block diagrams of a spatially multiplexed transmitter and receiver implementing a space-division multiple access protocol (SDMA), according to an embodiment of the current invention.

FIGS. 13A–B are process flow diagrams showing the acts associated with respectively the spatially multiplexed transmission and reception of datastream(s) in any one of a number of multiple access protocols, according to an embodiment of the invention.

DETAILED DESCRIPTION OF THE EMBODIMENTS

A method and apparatus is disclosed which allows for both spatial multiplexed and non-spatial wireless communications between portable units and corresponding selected ones among a plurality of base stations. The methods and apparatus of the current invention may be implemented on a dedicated wireless infrastructure or may be superimposed on existing wireless communications systems, such as cellular telephone and paging services, which are currently in place around the world. The methods and apparatus include implementation in any of a number of multiple access protocols.

Spatial Multiplexing and Multiple Access

Spatial multiplexing (SM) is a transmission technology which exploits multiple antennas at both the base station(s) and at the subscriber units to increase the bit rate in a wireless radio link with no additional power or bandwidth consumption. Under certain conditions, spatial multiplexing offers a linear increase in spectrum efficiency with the number of antennas. Assuming, for example, $N=3$ antennas are used at the transmitter and receiver, the stream of possibly coded information symbols is split into three independent substreams. These substreams occupy the same channel of a multiple access (MA) protocol, the same time slot in a time-division multiple access (TDMA) protocol, the same frequency slot in frequency-division multiple access (FDMA) protocol, the same code/key sequence in code-division multiple access (CDMA) protocol or the same spatial target location in space-division multiple access (SDMA) protocol. The substreams are applied separately to the N transmit antennas and launched into the radio channel. Due to the presence of various scattering objects (buildings, cars, hills, etc.) in the environment, each signal experiences multipath propagation. The composite signals resulting from the transmission are finally captured by an array of receive antennas with random phase and amplitudes. For every substream the set of N received phases and N received amplitudes constitute its spatial signature.

At the receive array, the spatial signature of each of the N signals is estimated. Based on this information, a signal processing technique is then applied to separate the signals, recover the original substreams and finally merge the symbols back together. Linear or nonlinear receivers can be used

providing a range of performance and complexity trade-offs. A linear spatial multiplexing receiver can be viewed as a bank of superposed spatial weighting filters, where every filter aims at extracting one of the multiplexed substreams by spatially nulling the remaining ones. This assumes, of course, that the substreams have different signatures.

If the transmitter is equipped with M antennas, while the receiver has N antennas, the rate improvement factor allowed by spatial multiplexing is the minimum of these two numbers. Additional antennas on the transmit or receive side are then used for diversity purposes and further improve the link reliability by improving, for example, the signal-to-noise ratio or allowing for smaller fading margins, etc. Effectively spatial multiplexing allows a transmitter receiver pair to communicate in parallel through a single MA channel, hence allowing for a possible N -fold improvement of the link speed. More improvement is actually obtained if we take into account the diversity gain offered by the multiple antennas (for instance, in a Raleigh fading channel). Such performance factors are derived ideally under the assumption that the spatial signatures of the substreams are truly independent from each other. In reality, the level of independence between the signatures will determine the actual link performance. The performance, however, usually exceeds that obtained by a single antenna at the transmitter and receiver. For example, at two GHz, assuming the base station and the subscriber unit are spaced apart by one mile and using three antennas at each end of the link, a scattering radius of about 30 feet (both ends) is enough to achieve maximum performance.

FIG. 1A shows a plurality of subscriber units wirelessly coupled over a cellular network to a network **100**. Network **100** may include: a local area network (LAN), a wide area network (WAN), a public switched telephone network (PSTN), Public Land Mobile Network (PLMN), an adhoc network, a virtual private network, an intranet or the internet. The wireless system includes: a central office (CO) **102**, a master switch center (MSC) **106**, a ground based relay station **110**, satellites (**112**), base stations **120**, **126** and **132** (BTS) and subscriber units **156**, **138**, **144**, **150** and **162**. The subscriber units may be mobile, fixed or portable. The base stations may be fixed or mobile. The base stations may include: a tower, satellites, balloons, planes, etc. The base station may be located indoors/outdoors. The cellular network includes one or more base stations, where each base station includes one or more spatially separate transmitters.

The central office **102** is coupled to the network **100**. Network **100** may be circuit switched (e.g. point-to-point) or packet switched network. The central office is coupled to a master switching center **106**. The MSC in traditional cellular systems is alternately identified as: a mobile telephone switching office (MTSO) by Bell Labs, an electronic mobile Xchange (EMX) by Motorola, an AEX by Ericsson, NEAX by NEC, a switching mobile center (SMC) and a master mobile center (MMC) by Novatel. The MSC is coupled via data/control line **108** to the satellites via relay station **110** and to the base stations. In an alternate embodiment of the invention, base station controllers (BSC) may serve as intermediary coupling points between the MSC and the base stations. In the embodiment shown, each of the BTS includes an array of spatially separate antennas for transmission and/or reception. The BTS may also include traditional antenna for whichever of the receive/transmit side of its communication capability lacks spatially separate antenna and associated circuitry. Antennas of a transmitter/receiver are defined to be spatially separate if they are capable of transmitting/receiving spatially separate signals.

Physically separate antenna may be used to transmit/receive spatially separate signals. Additionally, a single antenna may be used to transmit/receive spatially separate signals provided it includes the ability to transmit/receive orthogonal radiation patterns. Hereinafter, the phrase “spatially separate” shall be understood to include any antenna or transmitter or receiver capable of communicating spatially separate signals. The base stations are configured to communicate with subscriber units of a traditional type, i.e. those lacking either spatially separate transmission/reception as well as spatially enabled subscriber units, i.e. those including either or both spatially separate reception and transmission capabilities.

In operation, distinct subscriber datastream(s) **170**, **176** and **182** are received by CO **102**. The CO performs the initial routing of the data streams to the appropriate one of a plurality of MSCs which may be located across the country. The MSC performs several functions. It controls the switching between the PSTN or network **100** and the BTSs for all wireline-to-subscriber, subscriber-to-wireline and subscriber-to-subscriber calls. It processes/logic data received from BTSs concerning subscriber unit status, diagnostic data and bill compiling information. In an embodiment of the invention, the MSC communicates with the base stations and/or satellites with a datalink using the X.25 protocol or IP protocol. The MSC also implements a portion of the spatial multiplexing and multiple access processes/logic (SM_MA) **104B** of the current invention. Each BTS operates under the direction of the MSC. The BTS and satellites **112** manage the channels at the site, supervise calls, turn the transmitter/receiver on/off, inject data onto the control and user channels and perform diagnostic tests on the cell-site equipment. Each BTS and satellite also implement a portion of the SM_MA processes/logic **104C**. The subscriber units may be both traditional and spatially enabled and may still communicate over the system. Those subscriber units that are spatially enabled on either/both the transmit/receive side of communications implement SM_MA processes/logic **104D** as well.

The SM_MA processes/logic allow high bit rate communications with any of the SM_MA enabled subscriber units within existing bandwidth constraints and within any of the multiple access (MA) protocols common to wireless communications or combinations thereof. Those MA protocols include: time-division multiple access (TDMA), frequency-division multiple access (FDMA), code-division multiple access (CDMA), space-division multiple access (SDMA) and many other multiple access protocols known to those skilled in the art. The SM_MA processes/logic include the ability to selectively allocate spatially separate downlink or uplink capability to any spatially enabled subscriber within a multiple access environment. This capability allows, as to that subscriber, the elevation of bit rates well above those currently available. Thus, a whole new range of subscribers can be anticipated to take advantage of this capability. Utilizing this invention, it will be possible to provide a wireless medium for connecting workstations, servers and tele-video conferences using the existing cellular infrastructure with the adaptations provided by this invention. The SM_MA processes/logic involve splitting subscriber datastream(s) destined for spatial multiplexing into substreams and intelligently routing and re-routing the substreams during a call session so as to maintain consistent quality of service (QoS). The substreams are communicated on the same channel using the same access protocol, thus not requiring additional resources or bandwidth to implement. The processes/logic include: access protocol assignment,

channel assignment, monitoring of spatial separation, determination/re-determination of spatial signatures for each communication link, routing/re-routing between single-BTS and multi-BTS, handoff and control of substream parsing/combining.

In FIG. 1A, datastream(s) **170**, **176** and **182** are shown originating on network **100**. The SM_MA processes/logic **104** have parsed and routed subscriber data stream **170** into substreams **172–174**, which are transmitted on a single channel of a multiple access protocol over the spatially separate antenna **134–136** of BTS **132**. Subscriber unit **138**, via spatially separate antenna **140–142**, receives composite signals **172–174** resulting from the substream transmission and utilizing SM_MA processes/logic **104D**, derives the substream and original datastream **170** therefrom. In the embodiment shown, the data is delivered to the computer **190** to which the fixed subscriber desktop unit **138** is coupled. The cellular environment may also be implemented utilizing aerial equivalents of the base stations. In the embodiment shown, a plurality of satellites **112** generally deliver subscriber datastream(s) via spatially separate antennae on each of the satellites to a cellular network, i.e. **114**.

In a circuit-switched embodiment of the invention, a call over a cellular network may require using two channels simultaneously; one called the user channel and one called the control channel. The BTS(s) transmit and receive on what is called a forward/downlink control channel and the forward/downlink voice/data channel and the subscriber unit transmit/receive on the reverse/uplink control and voice/data channels. Completing a call within a cellular radio system is quite similar to the PSTN. When a subscriber unit is first turned on, it performs a series of startup procedures and then samples the received signal strength on all user channels. The unit automatically tunes to the channel with the strongest receive signal strength and synchronizes to the control data transmitted by the BTS(s). The subscriber unit interprets the data and continues monitoring the controlled channels. The subscriber unit automatically re-scans periodically to ensure that it is using the best control channel. Within a cellular system, calls can take place between a wireline party and a subscriber unit or between two subscriber units. For wireline-to-subscriber unit calls, the MSC receives a call from either a wireline party or in the form of a call setup packet from the network **100**. The MSC determines whether the subscriber unit to which the call is destined is on/off hook. If the subscriber unit is available, the MSC directs the appropriate BTS to page the subscriber unit. The subscriber unit responds to the BTS indicating its availability and spatial multiplexing capabilities, receive and/or transmit. Following the page response from the subscriber unit, the MSC/BTS switch assigns an idle channel, configures spatial processing capability on both the subscriber unit and BTS(s) if appropriate, and instructs the subscriber unit to tune to that channel. The subscriber unit sends a verification of channel tuning to the BTS(s) and then sends an audible call progress tone to the subscriber I/O unit causing it to ring. The switch terminates the call progress tone when it receives positive indication the subscriber has answered and the conversation or communication has begun.

Calls between two subscriber units are also possible in the cellular radio system. To originate a call to another subscriber unit, the calling party enters the called number into the unit's memory via the touch pad and then presses the send key. The MSC receives the caller's identification number and the called number then determines if the called unit is free to receive the call. The MSC switch sends a page

command to all base stations and the called party, who may be anywhere in the service area, receives the page. The MSC determines the spatial multiplexing capability of both subscribers. Following a positive page from the called party, the switch assigns each party an idle user channel and instructs each party to tune into that respective channel. Then the called party's phone rings. When the system receives notice the called party has answered the phone, the switch terminates the call progress tone and a communication can begin between two subscriber units. If spatial multiplexing is enabled, the communication link will include that capability.

One of the most important features of the cellular system is its ability to transfer calls that are already in progress from one cell site/base station to another as a subscriber unit moves from cell to cell or coverage area to coverage area within the cellular network. This transfer process is called a handoff. Computers at the BTS transfer calls from cell to cell with minimal disruption and no degradation in quality of transmission. The handoff decision algorithm is based on variations in signal strength. When a call is in progress, the MSC monitors the received signal strength of each user channel. If the signal level on an occupied channel drops below a predetermined threshold for more than a given time interval, the switch performs a handoff provided there is a vacant channel. In a traditional non-SM cellular system a traditional handoff involves switching the transmission point of a subscriber session (datastream) from one BTS to another. In the current invention various types of handoff, e.g. partial and full may take place. The handoff operation may involve the MSC re-routing the call and the entire datastream or selected substreams thereof to different antennas of the same BTS or to a new BTS/BTSs in whole or in part. Where the re-routing is partial, at least one substream communication path is left unchanged while other of the substreams are re-routed to antennas on another BTSs. Where the handoff is full the multiple substreams transmitted from one or more BTSs are re-routed to other BTS(s).

In an embodiment of the invention utilizing a packet switched architecture, call setup may be implemented using protocols including: ALOHA, slotted-ALOHA, carrier sense multiple access (CSMA), TDMA, FDMA, CDMA, SDMA, etc., or any combination thereof.

BTS 132, in the embodiment shown, includes spatially separate antenna array. There may be any number of antennas. In some spatial environments, baud rates for spatially multiplexed communications on a single channel will increase linearly with the number of antennas allocated by subscriber unit and BTSs to a call session. In the embodiment shown, each BTSs array includes at least two antennas 134 and 136. The BTS may include either or both spatial multiplexing capability on the downlink (transmit) or uplink (receive) side. In the embodiment shown, each BTS includes spatial multiplexing capability on both the downlink and uplink. Although each of the following embodiments utilizes two antennas to implement SM, any number of antennas on a single BTS or multiple BTSs may be utilized without departing from the scope of the invention.

FIG. 1B shows a more detailed view of the BTS and subscriber units shown in FIG. 1A. Each BTS includes two spatially separate antennas. BTS 120 includes antennas 122-124. BTS 126 includes antennas 128-130. BTS 132 includes antennas 134-136. In the embodiment shown, many of the subscriber units also include at least two spatially separate antennas. Subscriber unit 150 includes spatially separate antennas 152-154. In the embodiment shown, the MSC handles the routing of subscriber datastream(s) 170, 176 and 182 from network 100 to the

appropriate BTSs for transmission to the appropriate subscriber unit. In an embodiment of the invention, the SM_MA processes/logic include the ability to determine whether to implement or not implement spatial multiplexing (SM), based on either the presence/absence of SM capabilities in the corresponding subscriber unit and/or on the nature of the datastream. If, for example, the subscriber lacks SM capability on either or both the uplink/downlink, then the corresponding datastream will not be parsed into substreams. Alternately, even if the subscriber unit and BTS have SM capability on both downlink and uplink, certain types of datastream(s) may not require SM processing. Examples of these might include: traditional voice call sessions, call sessions which require only low QoS or datastream(s) which require only very low bit rates or are susceptible to buffering and delayed transmission.

In the example shown in FIG. 1B, datastream 182 is traditional mode traffic, e.g. a subscriber telephone call between an upstream subscriber and the subscriber unit 144. Subscriber unit 144 is located within a cell serviced by BTS 132. Under the control of MSC 106, the datastream 182 is transmitted over signal line 108 directly to the corresponding base station 132 without being split or parsed into associated substreams. In the example shown, datastream(s) 182 is transmitted from a single antenna, e.g. antenna 134, without any SM techniques. That transmission is received by the subscriber unit 144. As discussed above, subscriber unit 144 may be a traditional cell phone lacking SM capability. Alternately, subscriber unit 144 may be SM enabled but, nevertheless, receives the call in traditional mode after appropriately configuring itself to opt out of SM receive side processes/logic, electing instead traditional mode.

In the example shown, datastream(s) 170 is handled using SM_MA processes/logic 104_. The datastream 170 and/or substreams thereof, depending on the embodiment, is routed by the MSC to BTS 132. The processes/logic 104 provide to each antenna 134-136 of BTS 132 a single substream derived from the original datastream 170, on a common channel within the appropriate access protocol. Those substreams are received as composite signals by the spatially separate antenna 140-142 (see FIG. 2B) of subscriber unit 138. The subscriber unit 138, utilizing SM-MA processes/logic 104D, derives the substreams from the composite signals and combines these into the initially transmitted datastream(s) 170.

Datastream(s) 176 is also subject to SM_MA processes/logic 104_. The datastream 176 and/or substreams thereof, depending on the embodiment, is routed by the MSC, initially to BTS 132 for single-base transmission to subscriber unit 150. SM-MA processes/logic implemented collectively at the MSC 106 and BTS 132 result in the splitting/parsing of the datastream(s) 176 into substreams 178-180. Initially those substreams are received as composite signals by the spatially separate antenna 152-154 (see FIG. 2C) of subscriber unit 150. The subscriber unit 150, utilizing SM_MA processes/logic 104D, derives the substreams from the composite signals and combines these into the initially transmitted datastream(s) 176.

Implementing SM or SM_MA communications between the BTS and the associated subscriber unit may be either line-of-site (LOS) or multipath. Multipath communications are likely in environments, such as a city, where buildings and other objects deflect signals transmitted from the BTS many times before their arrival at the subscriber unit. Under certain conditions, it may be the case that transmissions originating from spatially separate antennas of a single BTS may arrive at a subscriber unit along signal paths which

cannot be spatially separated by the antenna array on the subscriber unit. Where this is the case, it may be necessary for the processes/logic to reconfigure the spatial transmission characteristics of the substreams so that they may be received at the corresponding portable unit in a manner which is spatially separable. In the example shown, the substreams **180** and **178_S** are transmitted initially from a single BTS **132**. When a determination is made, either by the BTS or subscriber unit that separation of the substreams is not possible, a spatial reconfiguration is initiated by the spatial multiplexing processes/logic **104**. The determination might, for example, result from the subscriber unit signaling the BTS or from the BTS determining that the bit error rate (BER) of the transmission exceeded an acceptable level. In an alternate embodiment of the invention in which base and subscriber communicate over a common channel, the signaling from the subscriber to the base station(s) for a change of a spatial transmission configuration is simplified. The BTS may, by analyzing the received signals, determine that they can not be adequately separated and in response, alter the spatial configuration of the transmissions to the subscriber unit with which it shares a channel. In the example shown, this reconfiguration results in a change of spatial configuration to multi-base transmission. Substream **178_M** is re-routed through BTS **120** and specifically antenna **122**. Because subscriber unit **150** is positioned in an area in which the transmissions from BTS **120** and **132** overlap, the change in spatial configuration is possible. The increased spatial separation on the transmit side increases likelihood that the substreams can be spatially separated by the subscriber unit **150** and its associated SM-MA processes/logic **104D**.

FIG. 1C shows another embodiment of the current invention in which a cell architecture which provides overlapping regions suitable for multi-base spatial multiplexing is shown. As in normal cellular structure, co-channel interference is avoided by ensuring that cells operating in the same frequency are spaced apart. In the example shown, BTSs **186A-C** form an overlapping region between them in which they are shown in spatially multiplexed communication with subscriber unit **138**. BTSs **186C-E** form an overlapping region between them, in which they are shown in spatially multiplexed communication with subscriber unit **150A**. BTSs **186C, F-G** also form an overlapping region between them, in which they are shown in spatially multiplexed communication with subscriber unit **150B**. The communications with subscriber units **138, 150A-B** are conducted on separate channels to avoid co-channel interference. Diversity techniques can be simultaneously implemented. More distant cells may re-use the same channels provided co-channel interference is tolerable.

FIGS. 2A-F show alternate embodiments of subscriber units which may be either fixed, portable or mobile. FIG. 2A shows a mobile cellular phone **144** with a single antenna **146**. In an embodiment of the invention, the single antenna includes the capability of transmitting and/or receiving spatially separable signals utilizing orthogonal di-poles. In an alternate embodiment of the invention, subscriber unit **144** is a traditional cellular phone which does not have the capability of transmitting/receiving a spatially separable signal. Either embodiment may be compatible with the system shown in FIGS. 1A-B, provided that system includes an embodiment of the invention with the ability to detect the transceiver capabilities of the subscriber units and to configure communications between that unit and the corresponding BTS accordingly.

FIG. 2B shows a fixed subscriber unit **138** coupled to a computer **190**. In this embodiment, high-speed data com-

munications between computer **190** and a wireless communication network with spatial multiplexing capabilities is enabled by fixed subscriber unit **138**. Fixed subscriber unit **138** is shown with an antenna array including antennas **140-142**. In the embodiment shown, additional antennas are provided. These may be utilized either for spatial multiplexing or to implement receive/transmit processing, e.g. diversity techniques, beam forming, interference cancellation, etc., the latter for the purpose of improving communication quality and link budget. The current state of the art requires a minimum separation between antennas **140-142**, i.e. D1 equivalent to $\frac{1}{2}$ the carrier wavelength. Further improvements in signal processing may avoid this requirement.

FIG. 2C shows a mobile subscriber unit, i.e. a cellular telephone **150**, reconfigured for implementation of SM or SM_MA on either or both of the transmit (uplink) or receive (downlink) side of its communication with the BTSs. To this end, the antennas **152-154** are provided.

FIG. 2D shows a personal digital assistant (PDA) **200** and associated docking station **202** configured to implement SM or SM_MA communications on either or both the transmit and receive portions of its communications. To this end, the antenna array, which in the embodiment shown, includes two antennas **204-206** is provided. An example of personal digital assistants currently on the market that could be configured to utilize the current invention is the Palm Pilot **xx**TM product sold by 3Com Corporation.

FIG. 2E shows a mobile subscriber unit **210** implemented as part of an automobile **216**. The antenna array associated with this unit is not shown. The use of SM or SM_MA wireless communications between vehicles and base stations can provide such benefits as vehicle navigation, routing, and diagnostics.

FIG. 2F shows a notebook computer **220** configured for SM or SM_MA communication utilizing an antenna array with antennas **222-224** and associated hardware and processes/logic.

FIG. 3 is a detailed hardware block diagram of a subscriber unit **138** and a BTS **132**. The BTS **132** includes: a multiple access spatial transmitter **310**, a multiple access spatial receiver **330**, a controller module **320** and upstream processes/logic **300**, further details of which are provided in the accompanying FIGS. 4-5. The subscriber unit **138** includes: a multiple access spatially configured receiver **380**, a multiple access spatially configured transmitter **350** and a control unit **370**. The multiple access spatial transmitter **310** includes: a selector **312**, a final transmission stage **316** and optionally may include transmit processes/logic **314**. The final stage transmitter **316** is coupled to a spatially separate antenna array which includes antennas **134T-136T**.

In operation, the subscriber datastream(s) and/or substreams thereof are provided to the selector **312** from the upstream processes/logic **300**. Utilizing either in band or out of band control signals embodied in the datastream(s)/substreams themselves or separately communicated from the SM_MA processes/logic at the MSC **106** or elsewhere, the selector implements the MA protocol utilized by the wireless network. That protocol, as discussed above, may include: TDMA, FDMA, CDMA or SDMA, for example. The selector places each of the datastream(s)/substreams on the appropriate channel. Each of the datastream(s)/substreams are then passed through the optional transmit processes/logic, in which any of a number of well-known prior art signal processing techniques may be implemented to improve the quality of transmission. These techniques include, but are not limited to, diversity processing, space-

time coding, and beam forming. The datastream(s)/substreams are then passed to the final transmit stage **316**. Traditional mode traffic may be routed by the SM_MA processes/logic **104_** to the appropriate antenna **134T–136T** for transmission. If diversity processing is implemented, even traditional mode traffic may be transmitted using multiple antennas. Spatial mode traffic, i.e. the individual substreams thereof, will be routed to the appropriate one of the two antennas **134T–136T**.

On the receive side, the subscriber unit SM_MA configurable receiver **380** includes: receiver first stage **382**, optional receive processes/logic **384**, spatial/space-time processor **386**, decoder **388**, combiner **390** and I/O module **392**. The receiver first stage is coupled to a spatially separate antenna array, e.g. antennas **140R–142R**. Utilizing in/out of band control signals, the SM_MA configurable receiver **380** of the subscriber unit **138**, in the embodiment shown, may be configured for spatial/traditional mode signal reception on the requisite channel within the multiple access protocol. In the case of spatial mode communications, the antenna array, e.g. antennas **140R–142R**, detect downlink composite signals derived from the spatially separate transmission of the substreams through antennas **134T–136T**. These composite signals are down converted, demodulated and sampled by the receiver first stage **382**. The composite signals are then passed to the receive processing module **384** and may be subject to receive side processing if implemented. From the receive processing module, the composite signals are passed to the spatial processor **386**. The spatial/space-time processor via in/out band control signals is also configured to derive the appropriate number of substreams, i.e. equivalent to the number transmitted, from the BTS(s). Utilizing logic associated with space/space-time processing (see FIGS. **7A–D**), that processor, in conjunction with decoder **388**, generates estimated source substreams which are passed to the combiner **390**. The combiner **390** via in/out band control signals is also configured to combine the substreams into an estimated subscriber datastream(s) corresponding to that transmitted from the BTS **132**. The datastream(s) are passed to the I/O module for presentment/delivery as, e.g., audio, image or data. Where communications are asymmetric, the uplink may, in an embodiment of the invention, not include SM capability, leaving that capability to the downlink alone. This asymmetric capability may be implemented on either the downlink or the uplink without departing from the scope of this invention.

The uplink from the subscriber unit **138** to the BTS **132** may use the same or different hardware/firmware/processes/logic to that utilized for the downlink. In an embodiment of the invention, the uplink is traditional with no SM_MA capability. In the embodiment shown in FIG. **3**, the uplink includes both SM and MA processes/logic. The datastream(s) received by the I/O module **352** are passed to parser **354**. In an embodiment of the invention, the parser is configurable to generate a traditional datastream or a variable number of substreams thereof. In another embodiment of the invention, the parser parses all datastream(s) into a fixed number of substreams. Where there are no SM uplink capabilities there is no parser. In other embodiments of the invention, the configurable parser also includes a mode detector to determine whether the datastream(s) should be split into substreams. That determination, as discussed above, may be based on any number of criteria including, but not limited to, traditional vs. spatial mode, QoS, bit rate requirement, feasibility, etc. In such an embodiment, when the mode detector determines that spatial mode transmission of the datastream is appropriate, the parser will split the

datastream(s) into a plurality of substreams, the number of which may itself be configurable. These substreams are then passed to the selector **356**. The selector responsive to in/out of band control signals implements the appropriate access protocol, including the placement of the datastream(s) and/or substreams onto the appropriate channel within that protocol. The datastream(s) and/or substreams thereof are then optionally passed to transmit processes/logic **358**, which may implement any number of well-known prior art signal processing techniques, including the above discussed diversity methodology, to improve signal reception. The substreams and/or datastream(s) are then passed to the final transmit stage **360** where they are encoded, modulated, and up-converted for transmission on a single channel through spatially separate transmit antennas **140T–142T**. Composite signals corresponding thereto are received by antennas **134R–136R** of the SM_MA configurable receiver **330** of the BTS.

As discussed above, where the uplink is asymmetric, the BTS may not implement or require SM on the uplink. Nevertheless, in the embodiment shown, the receiver **330** is SM_MA configurable. The receiver **330** includes a first stage receiver **332**, mobility detector **334**, receive processes/logic **336**, spatial/space-time processor **338** and a decoder **340**. The composite signals are passed by antennas **134R–136R** to the first stage receiver. This is configurable to receive the communications on the appropriate channel within the MA protocol as determined by SM_MA processes/logic **104_**. These composite signals are down-converted/demodulated and sampled. In an embodiment of the invention, the mobility detector **334** monitors the composite signals for Doppler shift/spread. Doppler shift/spread of the composite signals correlates with the mobility or lack thereof of the subscriber unit. The absence of a Doppler shift/spread indicates that the subscriber unit is fixed. This determination on the part of the mobility detector may be used to initiate one or more of the following processes/logic: spatial reconfiguration, training/retraining of the spatial/space-time processors and/or handoff. In an embodiment of the invention in which non-blind in band training is implemented, training/retraining may include varying the training interval or duration or selection of a different training sequence. The composite signals are then passed to the optional receiver processes/logic **336**. These processes/logic, as described above, may include any of a number of well-known techniques including diversity processing. The composite signals are then passed to the configurable space/space-time processor **338**. Utilizing in/out of band control signals from the MSC and/or the subscriber unit, the space/space-time processor configures itself to generate a number of substreams or a single datastream(s) equivalent to those transmitted from the corresponding subscriber unit. These estimated subscriber substreams/datastream(s) are then passed to the decoder **340**. The decoder decodes the symbols to their corresponding binary equivalent. The datastream(s) and/or substreams are then passed to upstream processes/logic **300**.

Both the subscriber unit **138** and the BTS **132** are shown to include respectively control modules **370** and **320**. These control modules implement a subset of the control processes/logic **104** required to implement the SM_MA processes, such as training of the space/space-time processors **338** and **386**, etc.

Training

Training refers to the requirement that, in order to implement a space/space-time processing on the receive side of whichever link down/up is implementing SM, it is necessary

that the space/space-time processor be equipped with an appropriate model of the spatial characteristics of the environment in which the signals will be passed between the subscriber unit and the associated BTS(s). Different types of training methodology may be appropriate, depending on whether the subscriber units are fixed/mobile, and if mobile, depending on the speed at which they are moving. Where a subscriber unit is fixed, training may be accomplished on installation of the unit, at setup of a call or during a call session. Where a subscriber unit is mobile, training/retraining must take place continuously or intermittently. Training for a fixed subscriber unit may take place intermittently as well, although generally at a lower frequency than that associated with a mobile subscriber unit.

Training is generally categorized as blind or non-blind. Training is non-blind when it is incorporated intermittently/continuously using in/out of band training signals, e.g. known sequences such as Walsh codes, transmitted between subscriber unit and BTS(s). Training is blind when it takes place without such signals, relying instead on non-Gaussianity, CM, FA, cyclostationarity or the spatial structure, such as the array manifold. The performance of blind methods will, of course, be sensitive to the validity of structural properties assumed. An excellent reference on the subject, which is incorporated herein by reference as if fully set forth herein, is found in: "*Space-Time Processing for Wireless Communications*", Arogyaswami J. Paulraj and Papadias, IEEE Signal Processing Magazine, November 1997, at pages 49–83. In an embodiment of the invention, non-blind training methods are utilized to configure the space/space-time processors. Further details on the space/space-time processor will be provided in the following FIGS. 7A–D and accompanying text.

Control module 320 includes: processor 324, clock 326, training module 328 and memory 322 for the storage of weights/parameters for the space/space-time processor 338. Control module 370 in the subscriber unit 138 includes: processor 374, clock 376, training module 378 and memory 372 for the storage of weights/parameters for the space/space-time processor 386. In the embodiment of the invention shown in FIG. 3, the CPU implements the training portion of the control processes/logic 104. In alternate embodiments of the invention, the CPU may be utilized to implement other of the control processes/logic. In still other embodiments of the invention, the training portion of the control processes/logic is handled upstream at such locations as the MSC or the CO.

In an embodiment of the invention which implements non-blind training, the mobility detector 334 signals the CPU 324 when a subscriber unit exhibits minimal Doppler shift/spread, e.g. is fixed. In an embodiment of the invention, the CPU 324 directs the transmit module 310 to signal subscriber unit 138 at call setup, or at the start of a call session, to use stored parameters from an earlier training session or to process a setup training session transmitted by the BTS. In another embodiment of the invention, the CPU may reduce the frequency or duration of a training sequence responsive to a determination that the Doppler shift/spread is minimal.

On the BTS side, the training module 328 inserts a known training sequence, e.g. Walsh code, into the downlink transmissions and these are processed by the CPU 374 of the subscriber unit and weights derived therefrom which allow the space/space-time processor 386 to separate the training sequence spatially broadcast from the antenna array of the BTS(s). Similarly, where the uplink implements SM, the subscriber unit training module 378 inserts a known training

sequence into the uplink transmissions as well. These are in turn processed by the CPU 324 and appropriate weights derived therefrom stored in the spatial processor 338 for use with the uplink communications during the call/data-transfer session. Whenever training/re-training takes place, weights are recalculated and stored for use in subsequent SM communications.

Where the mobility detector 334 determines that the subscriber unit is mobile, an alternate non-blind training methodology may be implemented. In an embodiment of the invention, that methodology shown in FIG. 8 involves inserting into in/out of band downlink communications the known training sequence. This allows updating of the spatial parameters/weights by the corresponding subscriber unit and its space/space-time processor. This capability allows spatial multiplexing to be implemented in both a mobile and a fixed environment. In still another embodiment of the invention, the duration/frequency at which the training intervals are inserted into the up/down link communications may be varied depending on the mobility of the subscriber unit.

In still another embodiment of the invention, blind training methods may be implemented. These unsupervised methods do not need training signals because they exploit the inherent structure of the communication signals.

As will be obvious to those skilled in the art, the processes/logic 104 and the associated modules/blocks discussed above and in the following disclosure may be implemented in hardware, software, firmware or combinations thereof without departing from the teachings of this invention. They may be implemented on a single chip, such as a digital signal processor (DSP), or application specific integrated circuits (ASIC). On the upstream side (i.e., BTS, MSC, CO, etc.), the SM_MA processes/logic 104 may physically reside in any one or all upstream units. The processes/logic may be implemented using master-slave control relationship between CO/MSB and BTS or peer-to-peer control relationship between BTSs alone, or distributed control between CO/MSB and BTS.

FIGS. 4A–F show an embodiment of the BTS/MSB/CO side of the processes/logic 104 for implementing SM_MA. FIGS. 4A–B and 4D–E show a partial handoff.

FIG. 4A shows BTSs 120 and 132 coupled to MSB 106 and to the associated upstream processes/logic 300 of processes/logic 104. The BTS 120 is shown with the associated final transmission stage 316B and the selector 312B. The BTS 132 is shown coupled to the final transmission stage 316A and to the selector 312A. The upstream processes/logic 300 include a detector 400, parser unit 402 and router 420. The parser unit 402 includes a parser module 404 and clock 406 as well as a stretcher 408 and its clock 410. The MSB 106 is shown coupled via its data/control line 108 to each of the above-discussed modules.

As will be obvious to those skilled in the art, the coupling between the MSB and each of the above-discussed hardware and software modules represents a master/slave embodiment of the current invention. In alternate embodiments of the invention, peer-to-peer control methodology may be utilized instead. In still another embodiment of the invention, distributed control methodology may be implemented, e.g. each of the above-discussed modules may contain additional intelligence, sufficient to signal downstream/upstream modules as to the appropriate configuration to adopt, responsive to the datastream(s)/substreams being processed, the channel and access methodology to be utilized.

Datastream(s) 176 is delivered to mode detector 400. In this embodiment of the invention, a mode detection is

utilized. As discussed above, this module provides the capability of distinguishing datastream(s). Datastream(s) might, as discussed, be categorized as traditional vs. spatial, or on the basis of QoS or bit rate requirement. In the embodiment shown, the detector **400** determines that the datastream(s) **176** is destined for spatial mode processing. Responsive to that determination, the parser **404** is configured to parse the datastream(s) **176** into a plurality of the substreams. In the example shown, the two substreams **450–452** are generated by the parser. The substreams each contain a portion of the actual data from the original datastream(s). The function of the stretcher **408**, to which the substreams are passed, is to effectively lower the baud rate at which the substreams are transmitted. Figuratively, this is accomplished by clocks **406** and **410** which are coupled to respectively the parser and the stretcher. Clock **410** operates at a rate which is a fraction of the rate of clock **406**. The specific fraction is determined by the number of substreams generated by the parser **404**. For example, if parser **404** generates from a single datastream(s) two substreams, then each of the substreams will be transmitted at a baud rate which is effectively $\frac{1}{2}$ that of the original datastream(s). The stretched substreams are then passed to the router **420**. In an alternate embodiment of the invention, the substreams need not be stretched, rather buffered and transmitted at the same baud rate in bursts, if the channel will support the resultant communication rate. The router operating, in the embodiment shown, under the control of the MSC **106** sends the selected substreams **454** and **456** to a single BTS **132** for single-base spatial transmission from each of the spatially separate antenna of that BTS. Those substreams passed through the selector **312** are injected on an appropriate channel within the multiple access protocol. The channel determination is made by the SM_MA processes/logic **104** that portion of which may be localized in a master/slave control implementation at the MSC. The substreams are then passed to the final transmission stage **316A** for transmission to the subscriber unit **150** (see FIG. 6).

FIG. 4B shows hardware/software modules identical to those discussed above in connection with FIG. 4A. The router **420**, responsive to a signal from, for example, the MSC **106** has re-routed one of the substreams to BTS **120**. That substream **454** is passed to the selector **312B** associated with BTS **120**. The corresponding substream **456** is presented to selector **312A** associated with BTS **132**. Under the control of the MSC, each selector is directed to place the substreams on the same MA channel on each of the base stations. The final transmission stages **316A–B** of each BTS places the substreams on one antenna of its spatially separate antenna array for transmission to the subscriber **150**. The subscriber **150** is in a location in which the signals from base stations **120** and **132** overlap. The composite signals **180** and **178_M** resulting from the transmission of spatially distinct subscriber substreams are received with spatially separable signatures by the subscriber unit **150** which, as discussed above, is equipped with spatially separate antennas.

The determination to move from a single-base spatial transmission (see FIG. 4A) to multi-base spatial transmission, as shown in FIG. 4B, may be made as a result of any one of the number of distinct determination methods. In the first of these methods, an evaluator portion of either the space/space-time processor **386** or the decoder **388** of the subscriber unit **138** determines that an incoming composite signal cannot be spatially separated into the required number of substreams. In response to this determination, the subscriber unit signals the BTS that a change of spatial configuration is required. This signal is processed by the BTS

and may be passed to the MSC **106**. In response, the MSC directs the router and selected BTSs, e.g. BTSs **120** and **132**, to prepare for and transmit the substreams on an assigned channel. This transition from single-base to multi-base spatial transmission is handled transparently to the subscriber, in order to maintain a consistent QoS throughout the transmission by increasing the spatial separation of the transmitted substreams.

FIG. 4C shows an alternate embodiment of the invention that includes the capability of mode detecting between, for example, traditional and spatial mode datastreams. Datastream(s) **182** is presented to detector **400** via data/control line **108**. The datastream(s) might, for example, be a traditional subscriber telephone call or a datastream which has both a low bit rate and QoS requirement. To minimize resources, it may be advantageous for the parser unit **402** to be configurable, so as not to subject all incoming datastream(s) to parsing or, if parsed, so as not to parse into a fixed number of substreams. In the embodiment shown, such capability is implemented. The detector determines that the datastream is traditional mode. That determination may result in the parser avoiding the parsing of the datastream **182**. The datastream(s) **182** is passed unparsed to the router **420**. The router **420** passes the datastream(s) **182** to the selector **312A** of the associated BTS **132**. Under the control of the MSC the selector and the final transmissions stage **316A** inject the datastream(s) **182** on the appropriate channel of the appropriate multiple access protocol and transmit it via a selected one of the antennas, within the array from which it is received, by subscriber unit **144**. That subscriber unit may be a traditional mobile phone lacking any spatial transmission characteristics. Alternately, the subscriber unit may be spatially configurable as well (see FIG. 2A). In this latter case, BTS **132** injects a control signal to the spatially configurable subscriber unit **144** and, in particular, to the configurable space/space-time processor thereof, indicating that the incoming composite signals are to be treated as a single datastream(s). As will be obvious to those skilled in the art, traditional mode datastreams including, for example, traditional voice telephone calls, may be subject to SM.

As will be obvious to those skilled in the art, each of the above-discussed datastream(s) **178**, **176**, **182** may include multiple subscriber sessions, time-division multiplexed for example. In this case, all the above-mentioned methodology may be practiced successively on each of the subscriber sessions of a single datastream.

FIG. 4D shows multiple subscriber datastream(s) presented to the detector **400**. Specifically datastream(s) **176** and **182** are shown. The first of these datastream(s) is destined for spatial treatment and the second of these datastream(s) **182** is destined for non-spatial treatment. This determination is made by the mode detector **400** based on criteria including, but not limited to, those discussed above. The parsing unit **402** is, in this embodiment of the invention, configurable to concurrently handle multiple subscriber sessions. Upon receipt of control information received either directly from the detector **400** or indirectly from the MSC **106**, the parsing module **402** performs the following concurrent operations. The traditional mode datastream(s) **182** is left unparsed and passed directly to the router **420**. The spatial mode datastream(s) **176** is parsed by parser **404** into substreams **450–452**. These substreams are stretched in stretcher **408**, as discussed above, and passed to router **420**. The router **420**, operating under the control of the MSC, for example, directs each of the datastream(s) and substreams to a single BTS **132** and specifically the associated selector **312A** of that BTS.

These substreams generated by the parser are labeled 450-452. The substreams passed by the router are labeled 454-456. This change in reference number is meant to indicate that the initial parsing operation may be accompanied by a lowering of the bit rate or stretching of the clock on which these substreams are transmitted. As will be obvious to those skilled in the art, an alternate methodology for implementing the invention would be to maintain the same the bit rate, provided it was compatible with the bandwidth of the wireless channel on which the transmission was to take place, and to buffer the data accordingly for transmission in bursts, along with other similarly processed datastream(s)/substreams.

Under the direction of the MSC, for example, the selector 312A and final transmission stage 316A of BTS 132 transmit the substreams 454-456 on a common channel and, depending on the access methodology, may transmit the datastream(s) 182 on the same or another channel. Signal 182 is transmitted from an antenna of BTS 132 to subscriber unit 144. The individual substreams and the associated signals 180, 178_S of the spatial mode datastream(s) 176 are transmitted to the subscriber unit 150.

FIG. 4E shows an embodiment of the invention identical to that described and discussed above in connection with FIG. 4D. Router 420 re-routes one of the substreams 454-456 of the spatially processed datastream(s) 176 to form a multi-base spatial transmission configuration. That determination to re-route, as discussed above, may originate either from signals received from the corresponding one of the subscriber units which is unable to spatially separate the substreams or alternately may result from a determination by the BTS initially implementing single-base transmission that the bit error rate (BER) is unacceptably high. In this example, subscriber unit 144 continues to receive composite datastream(s) 182 from an antenna on BTS 132. The composite signals received by subscriber 150 now, however, originate from a multi-base configuration. The substream 454 has been re-routed by router 420 to BTS 120, so the composite signals 180, 178_M originate from BTSs 132, 120, respectively.

As will be obvious to those skilled in the art of the reference, in single or a multi-base spatial transmission, discussion to a substream been transmitted from a single antenna, should not be interpreted as a limitation on the teachings of this invention. A single substream in single or multi-base configuration may be transmitted from more than one antenna, if diversity or beam forming transmit processes are implemented in addition to spatial multiplexing.

FIGS. 4F-J show an alternate embodiment of the invention in which the router, as described and discussed above in connection with FIGS. 4A-E, is positioned upstream of the parsing unit rather than downstream of that unit. Consequently, each of the base stations has associated with it a corresponding parsing unit. FIGS. 4F-G and FIGS. 4I-J show a partial handoff.

FIG. 4F shows MSC 106, BTSs 120 and 132 and the upstream processes/logic 300. Each of the base stations 120 and 132 includes selectors and final transmission stages. Within the upstream processes/logic 300, the detector 400 communicates directly to the router 422. The router, in turn, communicates directly with the parsing units 402A-B associated with BTSs 132 and 120, respectively. Single-base spatial processing of subscriber datastream(s) 176 is shown. The subscriber datastream(s) 176 is received by the detector 400. The detector determines that the mode of the datastream(s) is spatial and that information is passed to the

router 422. The router routes the datastream(s) 176 to the appropriate parsing unit 402A. The parsing module 404A of that unit parses the datastream(s) into substreams, e.g. substreams 450-452. Those substreams are passed to stretcher 408A which is coupled to selector 312A. The selector places both the stretched substreams 454-456 on the appropriate channel of the selected MA protocol. Those substreams are transmitted by the final transmit stage 316A of the BTS 132. The signals 178_S and 180 are transmitted to subscriber unit 150, along with the control information necessary for that subscriber unit to properly process the incoming communication.

FIG. 4G shows a multi-base implementation of the configuration described and discussed above in connection with FIG. 4F. The detector 400 determines that the datastream(s) 454-456 require spatial processing. Additionally, multi-base transmission is determined to be necessary based, for example, on a subscriber unit signal or on the BER detected by a BTS. The router 422, responsive to that determination, routes the datastream to parsing units 402A-B. Each of the parsing modules 404A-B is presented information, not only that the datastream(s) needs to be parsed, but also which substreams are to be discarded at each parsing unit in order to implement a multi-base spatial transmission. In an embodiment of the invention, those in control instructions are generated by the MSC 106. The parsing module 404A generates substream 452. The parsing module 404B generates substream 450. Collectively, substreams 450-452 contain all the information from the original datastream(s) 176 from which they were parsed. The selected substreams are passed to the corresponding stretching modules 408A-B. These stretching modules in turn pass the substreams with a reduced bit rate or in bursts as substreams 456-454 to the corresponding selectors 312A-B of the associated BTSs 132 and 120. The substreams are placed on the same channels of the multiple access protocol implemented by each BTS. These substreams are transmitted by the corresponding final transmissions stages 316A-B. Signal 180 corresponding to substream 456 is transmitted by at least an antenna on BTS 132 to subscriber unit 150. Signal 178_M corresponding to substream 454 is transmitted by at least an antenna of BTS 120 to subscriber unit 150. The inclusion of both single-base and multi-base spatial transmission capabilities in the system allows consistent QoS to be delivered to the subscribers.

FIG. 4H shows an implementation of the current invention in which the detector 400 includes the capability of distinguishing the mode of the datastream(s), e.g. traditional mode and spatial mode. The detector 400, upon determining that datastream(s) 182 can be processed in traditional mode, passes that information to the router 422. The router passes the datastream(s) 182 to the appropriate parsing unit 402. The parser unit 402A and specifically parser module 404A thereof avoids parsing the datastream(s) and passes it to the corresponding selector 312A associated with BTS 132. In the manner described and discussed above, the channel and antenna on which that datastream(s) is to be transmitted from BTS 132 is determined by the processes/logic 104, e.g. at the MSC. The associated signal 182 is passed from the BTS to the subscriber unit 144.

FIG. 4I shows the introduction of multiple subscriber datastream(s), i.e. datastream(s) 176 and 182 into the embodiment described and discussed above in connection with FIGS. 4F-H. The detector 400 determines that datastream(s) 182 may be processed in the traditional mode while datastream(s) 176 may be processed in the spatial mode. In this example, both the datastream(s) are routed by router 422 to a single BTS for, respectively, non-spatial and

spatial transmission. Stretched datastream(s) 454–456 derived from substreams 450–452 of datastream(s) 176 are presented to the selector associated with BTS 132. Signals 178_S and 180 are transmitted to subscriber unit 150 on the same channel of the MA protocol implemented by the BTS. Traditional mode datastream(s) may be transmitted on the same or another channel.

FIG. 4J shows a multi-base spatial transmission of the datastream(s) 176 discussed above in connection with FIG. 4I. A change from single to multi-base transmission is initiated by the processes/logic 104_ in response to, for example, a degradation in the bit error rate or to signals from subscriber unit 150 which indicate that a change in spatial configuration is required. This might include changing the antenna selection on the array of a single BTS. The selection might involve a reduction/increase in the number of transmitting antennas. Alternately, in the example shown, a partial handoff is implemented. To implement the partial handoff, router 422 routes the datastream(s) 176 to both parsing units 402A–B. Control information, indicating which of the substreams generated by the respective parsing unit is to be passed on to the associated BTS, may also be generated. Responsive to that information, the parsing modules 404A–B each generate only one of the substreams which can be generated from the datastream(s) 176. Each selected substream is stretched by the corresponding stretcher and passed to the corresponding BTS. BTS 132 continues to transmit the traditional mode datastream(s) 182 and the signal corresponding thereto to subscriber unit 144. BTS 132 transmits one of the stretched substreams 456 in the form of signal 180 to subscriber unit 150. The other of the substreams 454 is passed to the subscriber unit 150 as signal 178_M from the BTS 120.

As will be obvious to those skilled in the art, the above-mentioned arrangements of detector, router and parsing units represent only some of the possible configurations of these modules/logic which may be utilized to implement the current invention. In an embodiment of the invention, the wireless network may not support both traditional and spatial transmission together. In that embodiment, the detector may not be required, since all datastream(s) will be handled by spatially transmitting them. In still another embodiment of the invention, multi-base operation may not be implemented, allowing only for single-base SM. In still another embodiment of the invention, the routing may be accomplished by a single BTS which uses in/out of band channels to wirelessly relay one or more substreams to other BTSs for re-transmissions on the assigned channel.

FIGS. 5A–B show the upstream modules associated with the processing of datastream(s) and substreams received by the BTSs. That information may be destined for another subscriber unit or for the network 100 (see FIG. 1A).

FIG. 5A shows the base stations 120,132, the upstream processes/logic 300 and the MSC 106. In the example shown, single-base SM is implemented. The subscriber unit 150 is shown transmitting signals 178_S and 180. These are received by BTS 132 and processed by the associated modules of its configurable SM receiver 330 (see FIG. 3). From the decoder 340A, substreams 454–456 are passed to the upstream processes/logic 300. The upstream module includes a router 420 and a combiner 500. The combiner 500 operates in reverse of the manner described and discussed above in connection with the parsing unit 402. The router 420 passes the substreams 454–456 to the combiner 500. The output of the combiner is the subscriber datastream(s) 176.

FIG. 5B shows the modules discussed above in connection with FIG. 5A during the reception of multi-base spatial

transmissions from the subscriber unit 150 as well as the single-base transmission from subscriber unit 144. BTS 132 and the associated receiver module 330, have their spatial processor configured to generate a single one of the substreams 456 that can be derived from the composite signals 178_M and 180 of subscriber unit 150. The other substream 454 is generated by corresponding modules associated with BTS 120. Additionally, on the same/different channel, BTS 132 with the receiver 330 is configured to generate a single datastream(s) 182 from the composite signal 182 transmitted by the subscriber unit 144. The datastream(s) 182 of the associated decoder of that BTS, i.e. decoder 340A is passed to the router 420. The combiner is configured to combine substreams 454–456 into datastream 176 and to pass datastream(s) 182 along without combining.

Thus, in an embodiment of the invention, the method and apparatus of the current invention may be used to implement SM_MA both on the down/up link. As will be obvious to those skilled in the art, SM may be asymmetrically implemented as well, on either the down/up link selectively, without departing from the scope of this invention.

FIG. 6 shows an antenna array of BTS transmitter 132 and the antenna array of the subscriber unit receiver 138 (see FIG. 3). The antenna array of the final transmissions stage 316 includes antennas 134T–136T. The antenna array of the first receiver stage 382 includes antennas 140R–142R. The first receiver stage passes the composite signals 640–642 to the space/space-time processor 386. The output of the processor is presented to the decoder 388 from which, as output, the substreams 454–456 are generated.

As will be obvious to those skilled in the art, the transmission of data through a wireless medium may involve modulation of an information signal derived from a datastream(s) or substream on a carrier signal. Information may, for example, be contained in the phase and/or amplitude relationship of the signal modulating the carrier. Each specific phase and/or amplitude relationship that is utilized is referred to as a “symbol”. The set of all symbols is referred to as the “constellation”. The greater the number of symbols in a constellation, the more binary bits of information may be encoded in each symbol in a given constellation. Current communication protocols allow for constellations with over 1024 symbols, each encoding for one of ten bit combinations. Antenna 134T is shown transmitting a symbol 600 within a signal constellation. This corresponds to an associated group of the bits corresponding to the data from a portion of substream 454. Antenna 136T is shown transmitting symbol 606 which corresponds to a different bit sequence derived directly from substream 456. The transmission of substream 454 by antenna 134 results in at least two signals 602–604. The transmission of the symbol 606 by antenna 136 generates at least two signals 608–610. Additional signals are likely in a multi-path environment with numerous scattering objects, such as buildings, etc. For the sake of simplicity, signals 602 and 610 transmitted from respectively antennas 134T–136T are both received by antenna 140R as a single composite signal. The corresponding signals 604 and 608 are received by antenna 142R as a single composite signal. In order for the spatial receiver of the subscriber unit to resolve the composite signals into the estimated subscriber datastream/substreams, the spatial processor 386 must include information about the spatial signatures 620–622 of the transmissions from each of the antennas 134–136. These spatial signatures may be determined using either blind and or non-blind training methods in the manner described and discussed above. By placing the decoder 388 downstream from the space/space-time proces-

sor **386**, the appropriate symbols may then be derived from the substream and converted into a corresponding binary sequence from which the corresponding portions of the substreams **454–456** may be generated.

As will be obvious to those skilled in the art, any of a number of other modulation techniques may be used to implement the current invention including: continuous phase modulation (CPM), continuous frequency modulation (CFM), phase shift keying (PSK), offset phase shift keying, amplitude shift keying (ASK), pulse position modulation (PPM), pulse width modulation (PWM), etc., without departing from the scope of this invention.

FIGS. 7A–B show an embodiment of the invention in which the spatial processor **386** is configured for both traditional and spatial mode signal reception. Additionally, in the spatial mode, the spatial processor is configurable to generate a variable number of substreams to correspond to the number transmitted. Spatial processor **386** and the decoder **388** are shown. The spatial processor **386** includes: first fabric switch **700**, first configurable logic **702**, second fabric switch **730**, second configurable logic **732**, an evaluator **740**, and a controller **746**.

The spatial processor **386** is coupled via the receive processes **384** to the receiver first stage **380** of the subscriber unit, as discussed above in connection with FIG. 3. Similar design applies to the spatial processor **338** in the BTS (see FIG. 3). The composite signal(s) detected by the first stage receiver is passed to the fabric switch **700** of the spatial processor. Responsive to signals generated by the control unit **746**, the first fabric switch passes the composite signal/signals to one or more of the sub-modules within first logic unit **702**. In the embodiment shown, a sub-module includes a multiplier **704** and a weight register **712**. The multiplier generates an output signal which is a product of the weight stored in weight register **712** multiplied by the incoming composite signal. The weights in this register and the register of other sub-modules may be derived using non-blind or blind training methods as discussed above. In the example shown in FIG. 7A, a composite signal **750** is presented to fabric switch **700**. This switch has been configured utilizing in/out of band control signals to process a single composite signal. The output of the multiplier is presented to the second fabric switch **730**. This fabric switch also is configurable by means of the control unit **746**. The fabric switch **730** presents the signals from the first logic module in variable configurations to one or more of the summers, e.g. summer **734** which is part of the second configurable logic in this embodiment of the invention. Because a single composite signal is being processed in the embodiment shown in FIG. 7A, only one summer is utilized. The input to that summer is the output of the multiplier **704** and the zero input provided by the control unit **746**. The output of the summer **734** is passed to the evaluator **740** (optional). The evaluator determines when signals that are spatially transmitted are not separable, and if separable, the quality of each link. The quality of each link may be evaluated using, for example, Signal to Interference Noise Ratio (SINR). The resultant traditional mode datastream(s) **182** is passed through the decoder. In the decoder the conversion from symbols to associated bit sequences is implemented. As shown above in FIG. 3, the output of the decoder is passed to an associated combiner. The configuration of the configurable spatial processor under the control of control unit **746** takes place as a result of in/out of band control signals. These signals may be generated during call setup or during an actual call session by SM_MA processes/logic **104**.

In FIG. 7B, the configurable nature of the spatial processor is evident by comparison to FIG. 7A. Composite signals **640–642** are presented to the first fabric switch **700**. Responsive to signals from the control unit **746**, the first fabric switch generates output signals for each of the composite input signals. Composite signal **640** is passed to a first pair of logic sub-modules within the first logic unit **702**. Composite signal **642** is passed to a second pair of logic sub-modules within the first logic unit **702**. The first pair of logic sub-modules include: multiplier **704** together with associated weight register **712**, and multiplier **706** together with associated weight register **714**. The second pair of logic sub-modules include: multiplier **708** together with associated weight register **716**, and multiplier **710** together with associated weight register **718**. Multipliers **704–706** receive as inputs the composite signal **640**. Multipliers **708–710** receive as inputs the composite signal **642**. The weight registers may contain weights obtained during transmission of a training sequence which allow training sequences to be separated. These are multiplied by the corresponding composite signal inputs and the four products are cross-coupled to summers **734–736** of the second logic unit **732** by the second fabric switch. The output of summers **734–736** is, respectively, the estimated substreams **454–456**. In the embodiment shown, these are passed through an evaluator **740** to the decoder **388**. Subsequently, the estimated substreams are combined into the original datastream **176** (not shown). The decoder **388** performs the above-mentioned function of mapping the summer output into symbols and from the symbols, into the appropriate binary sequences. In an alternate embodiment of the invention, the evaluator may be placed downstream of the decoder and perform a similar function at that location.

The evaluator monitors the estimated substreams to determine if they are appropriately separated, and if separable, the quality of the link(s). This determination might, for example, be made during the transmission of a training sequence. When the evaluator determines it is no longer possible to spatially separate the corresponding substreams, that determination may be passed to the upstream processes/logic **104**, e.g. the MSC **106** (see FIG. 1). This results in an alteration of the spatial configuration of the transmission. A change in spatial transmission may be implemented in any number of ways. These include: a change in the antenna selection and/or number at a single base, a change from traditional to spatial mode broadcasting at a single base, a change from single-base to multi-base transmission. Similarly, when the evaluator determines that the substreams are separable, it may pass on the link quality parameters to the upstream processes/logic **104**, e.g. the MSC **106**. This can help the BTS/MSC/CO side of the processes/logic **104** choose the modulation rate (bits per symbol) of each substream, and carry out parsing accordingly.

FIGS. 7C–D show an embodiment of space-time processor. To the capabilities of the above-discussed spatial processor is added the ability to remove the interference in the composite signal caused by the delayed versions of the composite signal over time. To account for these perturbations, one or more delay elements may be introduced into the signal paths in the first logic unit to account for these effects. An exploded view of an embodiment of a time logic sub-module is shown in FIG. 7D. In the embodiment shown, each time sub-module is coupled to the output of a corresponding multiplier in the first logic unit. Time sub-modules **720–726** are coupled to the outputs of multipliers **704–710**, respectively. Each time module may consist of a plurality of delay elements. In the exploded view, a

sub-module includes delay modules **760–762**; multipliers **770–772** together with associated weight registers **780–782**, as well as a summer **790**. The output of multiplier **704** is an input both to delay module **760** and summer **790**. The output of delay module **760** is an input both to delay module **762** and to multiplier **770**. The output of delay module **762** is an input to multiplier **772**. The outputs of the multipliers provide additional inputs to the summer **790**. The output of the summer is presented to the second fabric switch **730**. Each time module may include additional multipliers with associative delay units and weight registers. As was the case in FIGS. **7A–B**, the space-time processor in FIGS. **7C–D** is configurable. FIG. **7C** shows the processor configured for a single input composite signal **750**. FIG. **7D** shows the space-time processor configured for two composite input signals **640–642**.

The spatial/space-time processor of FIGS. **7A–D** is configurable; e.g. capable of processing a variable number of composite signals and outputting a corresponding number of estimated subscriber substreams. In another embodiment of the invention, the spatial/space-time processor is not configurable; accepting instead a fixed number of substreams and outputting a corresponding fixed number of estimated subscriber substreams.

As will be obvious to those skilled in the art, any of a number of other processing techniques may be used to implement the current invention, including: space-time, space-frequency, space-code, etc. In turn, these may further utilize any, or a combination of techniques including, but not limited to: linear or non-linear processing, Maximum Likelihood (ML) techniques, Iterative decoding/interference canceling, Multi-user detection (MUD) techniques, etc., without departing from the scope of this invention.

FIG. **8** shows a datastream interspersed with the training sequences consistent with a non-blind embodiment of the current invention. Training sequences **800–802** and data sequences **850–852** are shown. Suitable training sequences include orthogonal Walsh codes transmitted by the spatially separate antennas. The spatial/space-time processor of the receiver attempts to generate weights which separate the known Walsh code sequences. Those weights are then used in processing the subsequent datastream(s)/substreams. In an embodiment of the invention, the training sequences are inserted into the datastream at frequency/duty cycle, which depend on the mobility of the subscriber unit. In another embodiment of the invention, the training sequences vary in duration and are constant in frequency. The training sequences may be transmitted in/out of band. As the mobility of a subscriber increases, the frequency/duty cycle of the training sequences may be increased. The mobility of the subscriber unit can, as discussed above, be detected by Doppler shift/spread detected by the mobility detector **334** (see FIG. **3**) on the receive side of the base station, for example. When the subscriber unit is fixed, training may only be performed at, or before, call setup or at a relatively low frequency/duty cycle during a call/data session. In still other embodiments of the invention, no training sequences would be inserted into the datastream(s)/substreams, instead relying on blind training techniques discussed above.

FIGS. **9A–B** to **12A–B** show various access methodologies utilized to provide multiple-access spatial multiplexing in accordance with the current invention. The figures labeled with “A” show the transmit portion of each access method while the figures labeled with “B” show the receive side. FIGS. **9A–B** show SM time-division multiple access (TDMA). FIGS. **10A–B** show SM frequency-division multiple access (FDMA). FIGS. **11A–B** show SM code-division

multiple access (CDMA). FIGS. **12A–B** show SM space-division multiple access (SDMA). The modules disclosed herein on the upstream side, as well as the subscriber side, may be implemented in hardware/software. They may be implemented on a single chip, e.g. DSP or ASIC. The modules disclosed on the upstream side may be located in the BTS or further upstream, e.g. the MSC/CO. On the subscriber side the modules may be implemented in a single unit.

FIG. **9A** shows a slot selector **900**, a transmit processor module **314A** (optional), and a final transmit stage **316A**. In the embodiment shown, these are part of the above-discussed BTS **132** (see FIG. **1A**). Each of these modules is coupled to the control elements shown in FIG. **3**, i.e. training module **328**, mobility detector **334**, memory **322**, processor **324**, and clock **326**. These are coupled via signal/control line **108** to the MSC **106**. The mobility detector is, in an embodiment of the invention shown in FIG. **3**, part of the receive side of the BTS. It is shown in FIG. **9A** for purposes of clarity, since it interacts with the training module **328** and CPU **324** to detect and generate training sequences responsive to the mobility of the subscriber unit. Subscriber datastream **182** and substreams **454–456** derived from subscriber datastream **176** (see FIGS. **4A–J**) are shown as inputs to the slot selector **900**. In TDMA each subscriber session is allocated a specific time segment in which to be transmitted. Time segments are assigned in round-robin fashion. In the traditional public switched telephone network (PSTN), there are twenty-four time slots (a.k.a. channels/D0). The slot selector **900**, under the direct/indirect control of processes/logic **104** and implemented at, e.g. the MSC **106**, assigns the related substreams **454–456** to identical channels (TDMA slots) within the separate TDMA datastream(s) **902–904**, which are output by the slot selector. The traditional mode datastream **182** is assigned to a separate channel/slot within TDMA datastream **904**.

Each of the TDMA datastream(s) **902–904** is, in an embodiment of the invention, provided as an input to an optional transmit processing module **314A**. That module may implement any one of a number of well known prior art techniques for improving signal quality in a wireless network including: diversity, space-time coding, beam forming, etc.

The transmit processor **314A** (optional) includes, in the embodiment shown, diversity processing, space-time coding and beam-forming. Beam-forming exploits channel knowledge to direct transmissions to the location of the corresponding subscriber. Diversity may be implemented in: frequency, time, space, polarization, space/space-time, etc. The outputs of the optional transmit processor **314A** are provided as inputs to the final transmit stage **316A**. That stage includes encoder modulators **924–926**, operating off a common carrier **914** for processing each of the TDMA datastream(s) **902–904**. These modulated datastream(s) are passed to respective RF stages **934–936** and associated antennas **134T–136T** for spatially separate transmission of the individual substreams that they contain, e.g. **454–456**. Additional antenna arrays **940–942**, RF stages **930–932**, encoder/modulator stages **920–922** are used to implement any of the optional transmit processes.

FIG. **9B** shows the receive side of a subscriber unit **150** enabled for spatial multiplexing utilizing TDMA access. That unit includes: first receiver stage **382A**, receive processor **384A** (optional), spatial/space-time processor **386**, decoder **388**, combiner **390**, I/O module **392**, TDMA slot selector **978**, processor **374**, carrier recovery module **376**, memory **372**, and training module **378**. The first receiver

stage includes antennas **140R–142R** which are coupled via, respectively, RF stages **952–950** to demodulator/sampling modules **962–960**. The demodulator/sampling units operate off a common carrier **970**. An additional antenna array **946**, RF stage **954**, demodulator/sampling module **964**, and carrier generator **972** are utilized by the receive processor **384A** to implement: diversity processing, space-time decoding, beam-forming, etc.

In operation, the carrier recovery module **376** synchronizes the carriers **970–972** to the carrier frequency of the incoming composite signals **990–992**. The TDM slot selector **978** accepts a channel assignment from the BTS(s) and synchronizes the receive processes accordingly. The composite signals from each antenna are demodulated and sampled by the corresponding one of the demodulator/sampling modules **964–960**. The outputs of these modules provide inputs to the receive processor **384A**. The receive processor implements signal processing techniques which may complement one or more of the optional processes discussed above for the transmit side (see FIG. 9A). Each composite signal output by the receive processes/logic **384A** provides inputs to the spatial/space-time processor **386** (see FIGS. 7A–D). That processor, using parameters/weights derived from the above-discussed blind/non-blind training techniques, separates the composite signals into the appropriate number of estimated subscriber substreams, e.g. **996–998**. In configurable embodiments of the spatial/space-time processor, information received from the BTS(s) at the start of, or during, a call session configures the processor to generate a number of substreams that correspond to the actual number of substreams transmitted. Next, the estimated subscriber substreams are provided as inputs to a similarly configured decoder **388**. The decoder maps symbols utilized during the transmission of the substreams/datastream(s) into their binary equivalent. The decoder outputs the estimated subscriber substreams **454–456** to the combiner **390**. The combiner reverses the operation performed on the transmit side by the parser, generating thereby an estimated subscriber datastream **176**. This datastream is provided to the I/O module **392** for subsequent presentment to the subscriber as for example, an audio signal, a video signal, a data file, etc.

FIGS. 10A–B show a BTS implementing SM frequency-division multiple access (FDMA). In FDMA, each subscriber session, whether traditional or spatially processed, is provided with a single frequency slot within the total bandwidth available for transmission. The BTS includes: a frequency slot selector **1000**, a transmit processor module **314B** (optional), and a final transmit stage **316B**. In the embodiment shown, these are part of the above-discussed BTS **132** (see FIG. 1A). Each of these modules is coupled to the control elements shown in FIG. 3, i.e. training module **328**, mobility detector **334**, memory **322**, processor **324**, and clock **326**. These are coupled via signal/control line **108** to the MSC **106**. Subscriber datastream **182** and substreams **454–456** derived from subscriber datastream **176** (see FIGS. 4A–J) are shown as inputs to the frequency slot selector **900**. The selector **1000**, under the direct or indirect control of the MSC **106**, selects the appropriate frequency slot for the datastream(s)/substreams. This is represented in FIG. 10A by a final transmit stage which includes encoder/modulator clusters (**1020–1022**), (**1024–1026**), and (**1028–1030**), each of which modulates about a unique center frequency as determined by respective associated carriers **1010–1014**. Intermediate the frequency selector **1000** and the final transmit stage **316B**, is an optional transmit processing unit **314B** which may impose on the datastream(s)/substreams

additional signal processing utilizing antenna arrays **1040–1042** in conjunction with antennas **134T–136T**, as discussed above in connection with FIG. 9A.

Within the final transmit stage two spatially separate antennas **134T–136T** are shown. These are coupled via, respectively, RF stages **1034–1036** and summers (**1002–1004**), (**1006–1008**), to separate outputs of each of three encoder/modulator clusters. Each encoder/modulator cluster operates about a distinct center frequency. Each cluster contains a number of encoder/modulator outputs at least equivalent to the number of spatially separate antennas in the final transmit stage. Since there are two antennas in the example shown, each cluster contains at least encoding/modulating capability for processing two distinct substreams and for outputting each separately onto a corresponding one of the antennas for spatially separate transmission. The traditional mode datastream **182** is assigned to the first cluster with a center frequency determined by carrier **1010**. That datastream is output via summer **1006** on antenna **136T**. Each of the substreams **454–456**, parsed from a common datastream **176** (see FIGS. 4A–J) is passed to a single cluster for spatially separate transmission on a single center frequency corresponding, in the example shown, to the center frequency determined by carrier **1012**. The modules disclosed herein may be implemented in the BTS or further upstream, e.g. the mobile switching center. They may be implemented as hardware or software. They may be implemented on a single chip, e.g. DSP or ASIC.

FIG. 10B shows a subscriber unit **150** enabled for spatial multiplexing utilizing FDMA access methodology. That unit includes: first receiver stage **382B**, receive processor **384B** (optional), spatial/space-time processor **386**, decoder **388**, combiner **390**, I/O module **392**, frequency selector **1078**, processor **374**, carrier recovery module **376**, memory **372**, and training module **378**. The first receiver stage includes antennas **140R–142R**, which are coupled via RF stages **1052–1050**, respectively, to demodulator/sampling modules **1062–1060**. The demodulator/sampling units operate off a common frequency synthesizer **1070**. Additional antenna array **1046**, RF unit **1054**, demodulator/sampling unit **1064**, and frequency synthesizer **1072** are shown. Optionally, these may be utilized by receive processing unit **384B** to implement any of the receive processes discussed above in connection with FIG. 9B.

In operation, the carrier recovery module **376** synchronizes the carriers **1070–1072** to the carrier frequency assigned by the BTS for the subscriber session, i.e. the carrier frequency at which the composite signals **1090–1092** are transmitted. The composite signals from each antenna are demodulated and sampled by the corresponding one of the demodulator/sampling modules **1064–1060**. The outputs of these modules provide inputs to the receive processor/logic **384B**. The receive processor implements signal processing techniques which may complement one or more of those discussed on the transmit side (see FIG. 10A). Each composite signal output by the receive processor/logic **384B** provides inputs to the spatial/space-time processor **386** (see FIGS. 7A–D). That processor, using parameters/weights derived using the above-discussed blind/non-blind training techniques, separates the composite signals into the appropriate number of estimated subscriber substreams/datastream(s), e.g. **1096–1098**. In configurable embodiments of the spatial/space-time processor, information received from the base stations at the start of, or during a call session, configures the processor to generate a number of substreams/datastream(s) which correspond to the actual number of substreams/datastream(s) transmitted. Next, the

estimated subscriber substreams/datastream(s) are provided as inputs to a similarly configured decoder **388**. The decoder maps symbols utilized during the transmission of the substreams/datastream(s) into their binary equivalent. The decoder outputs the estimated subscriber substreams in their binary equivalent **454–456** to the combiner **390**. The combiner reverses the operation performed on the transmit side by the parser, generating thereby an estimated subscriber datastream **176**. This datastream is provided to the I/O module **392** for subsequent presentation to the subscriber as for example, an audio signal, a video signal, a data file, etc. As will be obvious to those skilled in the art, the subscriber unit may be configured to receive more than one channel concurrently.

FIGS. **11A–B** show a BTS implementing SM code-division multiple access (CDMA). In CDMA, each subscriber session, whether traditional (unparsed) or spatially processed (parsed), is provided with a distinct code sequence. The datastream/substreams are modulated (spread) onto the distinct code sequence/key code (Kn), and the spread signal is, in turn, modulated onto a common carrier. This has the effect of spreading each session across the entire transmission bandwidth. The BTS includes a key/code selector **1100**, a transmit processor module **314C** (optional), and a final transmit stage **316C**. In the embodiment shown, these are part of the above-discussed BTS **132** (see FIG. **1A**). Each of these modules is coupled to the control elements shown in FIG. **3**, i.e. training module **328**, mobility detector **334**, memory **322**, processor **324**, and clock **326**. These are coupled via signal/control line **108** to the MSC **106**. Shown here for ease of explanation, the mobility detector, as discussed above, is actually implemented on the receive side of the BTS and interacts with the training module **328** to inject training sequences into the SM_CDMA transmissions.

Subscriber datastream **182** and substreams **454–456** derived from subscriber datastream **176** (see FIGS. **4A–J**) are shown as inputs to the key/code selector **1100**. The selector **1100**, under the direct or indirect control of the MSC **106**, selects the appropriate key/code sequence for the datastream(s)/substreams. This is represented in FIG. **11A** by a final transmit stage which includes spreader and encoder/modulator clusters, (**1110–1111,1120–1121**), (**1112–1113,1122–1123**), and (**1114–1115,1124–1125**) each of which modulates over a unique key code, respectively **1116–1118**, and all of which modulate on a common carrier **1126**. Intermediate the code/key selector **1100** and the final transmit stage **316C** is the optional transmit processing unit **314C**, which may impose on the datastream(s)/substreams additional signal processing, such as that described and discussed above in connection with FIG. **9A**.

Within the final transmit stage, two spatially separate antennas **134T–136T** are shown, along with an optional antenna array **1140–1142** associated with transmit processing. These are coupled via, respectively, RF stages **1134–1136** and summers (**1102–1104**), (**1106–1108**) to separate outputs of each of three spreader encoder/modulator clusters. Each spreader encoder/modulator cluster operates about a distinct key code. Each cluster contains a number of encoder/modulator outputs at least equivalent to the number of spatially separate antennas in the final transmit stage. Since there are two antennas in the example shown, each cluster contains at least encoding/modulating capability for processing two distinct substreams and for outputting each separately onto a corresponding one of the antennas for spatially separate transmission. The traditional mode datastream **182** is assigned to the second cluster with the key code

1117. That datastream is output via summer **1104** on antenna **134T**. Each of the substreams **454–456**, parsed from a common datastream **176** (see FIGS. **4A–J**), is passed to a single cluster for spatially separate transmission with a single key code **1116**.

FIG. **11B** shows a subscriber unit **150** enabled for spatial multiplexing utilizing CDMA access methodology. That unit includes: first receiver stage **382C**, receive processor **384C** (optional), spatial/space-time processor **386**, decoder **388**, combiner **390**, I/O module **392**, key/code selector **1182**, processor **374**, carrier recovery module **376**, memory **372**, and training module **378**. The first receiver stage includes antennas **140R–142R**, which are coupled via, respectively, RF stages **1152–1150** to demodulator/sampling modules **1168–1166**. Demodulator/sampling modules **1168–1166** operate off a carrier **1172**. The output of these is passed to de-spreaders **1162–1160**, respectively, which operate off of key code **1176**, assigned by the key/code selector **1182** on the basis of control information passed between subscriber unit and base station. Carrier recovery and synchronization may be handled by carrier recovery module **376**, operating in conjunction with carrier generator **1172**. Additionally, first receiver stage **382C** includes optional antenna array **1146**, RF stage **1154**, demodulator/sampling unit **1170**, carrier generator **1174**, de-spreader **1164**, and key/code generator **1178**. These may be utilized in conjunction with the optional receive processor **384C** in the manner discussed above in FIGS. **9B** and **10B**.

In operation, the carrier recovery module **376** synchronizes the carriers **1172–1174** to the carrier assigned by the BTS for the subscriber session, i.e. the carrier at which the composite signals **1190–1192** were transmitted. The composite signals from each antenna are then demodulated and sampled by the corresponding one of the demodulator/sampling modules **1168–1166**. Respectively, the outputs of these modules provide inputs to de-spreaders **1162–1160**, where they are de-spread using the key code **1176** assigned for the session. The outputs of the de-spreaders provide inputs to the optional receive processor **384C**. The receive processor may implement signal processing techniques which complement one or more of those discussed on the transmit side (see FIG. **11A**). Each composite signal output by the receive processes/logic **384C** provides inputs to the spatial/space-time processor **386** (see FIGS. **7A–D**). That processor, using parameters/weights derived using the above-discussed blind/non-blind training techniques, separates the composite signals into the appropriate number of estimated subscriber substreams/datastream(s), e.g. **1196–1198**. In configurable embodiments of the spatial/space-time processor, information received from the base stations at the start of, or during, a call session configures the processor to generate a number of substreams/datastream(s) which correspond to the actual number of substreams/datastream(s) transmitted. Next, the estimated subscriber substreams/datastream(s) are provided as inputs to a similarly configured decoder **388**. The decoder maps symbols utilized during the transmission of the substreams/datastream(s) into their binary equivalent. The decoder outputs the estimated subscriber substreams **454–456** in their binary equivalent to the combiner **390**. The combiner reverses the operation performed on the transmit side by the parser, generating thereby an estimated subscriber datastream **176**. This datastream is provided to the I/O module **392** for subsequent presentation to the subscriber as, for example, an audio signal, a video signal, a data file, etc. As will be obvious to those skilled in the art, the subscriber unit may be configured to receive more than one channel concurrently.

FIGS. 12A–B show a BTS implementing space-division multiple access (SDMA). In SDMA, each subscriber session, whether traditional (unparsed) or spatially processed (parsed), is transmitted as a shaped beam; a high gain portion of which is electronically directed using beam forming toward a known subscriber, at a known location, within a cell. This has the effect of allowing channel re-use within a single cell by beam forming each subscriber session to a separate segment of a cell.

The BTS includes a beam steering selector **1200**, a transmit processor module **314D** (optional), and a final transmit stage **316D**. In the embodiment shown, these are a part of the above-discussed BTS **132** (see FIG. 1A). Each of these modules is coupled to the control elements shown in FIG. 3, i.e. training module **328**, mobility detector **334**, memory **322**, processor **324**, and clock **326**. These are coupled via signal/control line **108** to the MSC **106**. Subscriber datastream **182** and substreams **454–456**, derived from subscriber datastream **176** (See FIGS. 4A–J), are shown as inputs to the beam steering selector **1200**. The selector **1200**, under the direct/indirect control of the MSC **106**, selects the appropriate direction in which beam steering is to be carried out for each subscriber session and its associated datastream/substreams. Intermediate the beam steering selector **1200** and the final transmit stage **316D** is the optional transmit processing unit **314D**, which may impose on the datastream(s)/substreams additional signal processing, such as that described and discussed above in connection with FIG. 9A, with the exception of beam forming.

Within the final transmit stage, two pairs of spatially separate antennas **134TA/B–136TA/B** are shown. Additionally, antenna array **1240** associated with transmit processes **314D** is shown. The two pairs of antennas are coupled via, respectively, RF stages **1234,1230,1236,1232** to beam steering module **1202**. The beam steering module accepts as inputs the separately encoded and modulated outputs from encoder modulators **1220–1226**, each of which operated on a common carrier **1210**, and each of which handles a different substream/datastream. The steering of datastream **182** to subscriber **144** (see FIG. 1B), and of substreams **454–456** to subscriber **150**, is accomplished by beam steering unit **1202**. That unit, operating with a known location/channel for each subscriber, steers the output beams from the antennas so that they interfere in a manner which maximizes the gain appropriately. At the location of subscriber **144**, beam steering results in the composite signal corresponding to datastream **182** reaching a relative maximum, while the gain of the composite signals corresponding to the substreams **454–456** at that location is minimized. Beam steering also accomplishes the opposite effect at the location of subscriber unit **150**.

FIG. 12B shows a subscriber unit **150** enabled for spatial multiplexing utilizing SDMA access methodology. That unit includes: first receiver stage **382D**, receive processor **384D** (optional), spatial/space-time processor **386**, decoder **388**, combiner **390**, I/O module **392**, processor **374**, carrier recovery module **376**, memory **372**, and training module **378**. The first receiver stage includes antennas **140R–142R**, which are respectively coupled via RF stages **1252–1250** to demodulator/sampling modules **1262–1260**. Demodulator/sampling modules **1262–1260** operate off of a common carrier **1270**. Carrier recovery and synchronization may be handled by carrier recovery module **376** operating in conjunction with carrier generator **1270**. Additionally, the first receiver stage may also include: an antenna array **1246**, coupled via RF stage **1254** to a demodulator/sampler **1264**,

and associated carrier module **1272**. These operate under the control of receive processes **384D** to implement any of the receive processes discussed above in connection with FIG. 9B, 10B and 11B.

In operation, the carrier recovery module **376** synchronizes the carriers **1270–1272** to the carrier at which beam forming is conducted by the BTS(s). The composite signals from each antenna are then demodulated and sampled by the corresponding one of the demodulator/sampling modules **1262–1260**. The outputs of these modules provide inputs to the receive processor **384D**. Each composite signal output by the receive processes/logic **384B** provides inputs to the spatial/space-time processor **386** (see FIGS. 7A–D). That processor, using parameters/weights derived using the above-discussed blind/non-blind training techniques, separates the composite signals into the appropriate number of estimated subscriber substreams/datastream(s), e.g. **1296–1298**. In configurable embodiments of the spatial/space-time processor, information received from the base stations at the start of, or during, a call session configures the processor to generate a number of substreams/datastream(s) that correspond to the actual number of substreams/datastream(s) transmitted. Next, the estimated subscriber substreams/datastream(s) are provided as inputs to a similarly configured decoder **388**. The decoder maps symbols utilized during the transmission of the substreams/datastream(s) into their binary equivalent. The decoder outputs the estimated subscriber substreams in their binary equivalent **454–456** to the combiner **390**. The combiner reverses the operation performed on the transmit side by the parser, generating thereby an estimated subscriber datastream **176**. This datastream is provided to the I/O module **392** for subsequent presentation to the subscriber as, for example, an audio signal, a video signal, a data file, etc. As will be obvious to those skilled in the art, the subscriber unit may be configured to receive more than one channel concurrently.

Although FIGS. 9–12 show four distinct multiple access methods, it will be obvious to those skilled in the art that each of these may be combined with one or more of the others without departing from the scope of this invention, as well as with such multiple access methods as: orthogonal frequency division multiple access (OFDMA), wavelength division multiple access (WDMA), wavelet division multiple access, or any other orthogonal division multiple access/quasi-orthogonal division multiple access (ODMA) techniques.

FIGS. 13A–B show the process flow for transmit and receive processing/logic **104** associated with an embodiment of the current invention. These processes/logic may be carried out across multiple datastreams, either in parallel, serially, or both. Processing begins at process block **1300** in which the next datastream is detected. Control then passes to decision process **1302**. In decision process **1302** a determination is made as to the mode of the datastream. As discussed above, the mode determination may distinguish traditional/spatial, quality of service, bit rate, etc. as well as various combinations thereof. If a determination is made that the mode is traditional, control passes to process **1304**. In process **1304** a routing determination is made for the datastream. The routing decision may involve the MSC directing the datastream to an appropriate one of the base stations for transmission. Control then passes to process **1306**. In process **1306**, the datastream is placed on the appropriate channel within the access protocol implemented on the wireless network. Channel assignment may also be made by the MSC. Control then passes to process **1308** in

which the subscriber datastream is transmitted. Next, in decision process **1310**, a determination is made as to whether any handoff from one BTS to another is appropriate. If this determination is in the affirmative, control returns to process **1304** for re-routing of the datastream. Alternately, if a negative determination is made in process **1310** that the subscriber is fixed, or still within the cell associated with the transmitting BTS, then control returns to process **1300** for the processing of the next datastream.

If, alternately, in decision process **1302** the mode of the next datastream is determined to be spatial, control passes to process **1320**. In process **1320** the datastream is split into a configurable number of substreams. Control is then passed to process **1322**. In process **1322** the individual substreams are routed and to one or more base stations for transmission to the subscriber. Control then passes to process **1324**. In process **1324**, under the direct or indirect control the MSC (see FIG. 1A), the access channel on which to transmit the substreams is selected. That information is communicated to the BTS(s) which are involved in the transmission of the substreams. Control then passes to decision process **1326**. In decision process **1326** a determination is made as to whether the intended subscriber is mobile or fixed. If a negative determination is reached, i.e. that the subscriber is fixed, control passes to process **1328**. In process **1328**, a training sequence either at set-up or during a call session is generated provided non-blind training protocols are being utilized. The receipt of these training sequences by the subscriber unit allows that unit to derive appropriate weight parameters in the first logic unit of the spatial/space-time processor for separating the composite signals into individual estimated substreams (see FIGS. 7A-D). Alternately, if in decision process **1326** an affirmative determination is reached, i.e. that the subscriber is mobile, then control is passed to process **1330**. In process **1330**, the frequency or duration of the training sequences inserted into the datastream is increased appropriately. This allows the subscriber unit to continually re-train its spatial/space-time parameters to account for possible changes in the spatial environment brought about by its motion. Control is then passed to process **1332**. In process **1332** a determination is made as to the number of substreams that are to be transmitted. The subscriber unit is then signaled as to the number of substreams for which it should configure its spatial/space-time processor and other modules. Control is then passed to process **1334**. In process **1334** the selected BTS(s) transmit the selected substreams to the corresponding subscriber unit. Control is then passed to decision process **1336**.

In decision process **1336**, a decision is made as to whether signal separation at the subscriber unit is adequate. As discussed above, this determination may, for example, be based on feedback from the subscriber unit by monitoring the received signal stream from the subscriber unit, or by monitoring bit error rate (BER) at the transmitting BTS(s). Numerous other methods will be evident to those skilled in the art for making this determination. If this decision is in the negative, i.e. that the subscriber unit is unable to separate the substreams, control returns to process **1320**. The process **1320** may now parse the data stream into lesser number of substreams than before, or may do parsing as before, then pass the control to process **1322** for re-routing of the datastream's substreams. Re-routing might, for example, include a change of spatial configuration on a single BTS, or a changeover from single-base to multi-base transmission, as discussed above in connection with FIGS. 4-J. Alternately, if in decision process **1336** an affirmative determination is reached that the subscriber unit is able to

separate the substreams, control passes to decision process **1338**. In decision process **1338** a determination is made as to whether a handoff is required. This may result in a partial or full handoff. If that determination is in the negative, e.g. the subscriber unit is fixed, or still within the cell and is capable of separating the substreams, then control returns to process **1300** for the interception of the next datastream. Alternately, if that decision is in the affirmative, control returns to process **1320**. The process **1320** parses the datastreams as before, and passes the control to process **1322** for re-routing of the substreams to one or more base stations.

FIG. 13B shows the receive processes/logic of a subscriber unit associated with an embodiment of the invention. Processing begins at process **1350**, in which the next datastream is first detected. Control is then passed to decision process **1352**. In decision process **1352**, a control signal from the BTS is received indicating the mode of the transmitted signal, e.g. traditional/spatial, and in the latter case, the number of substreams to be generated from the composite signals received. If the composite signals are to be treated as carrying a traditional datastream, control is passed to process **1354**. In process **1354** the appropriate channel on which to receive the composite signal is assigned. Channel assignment may occur: during call setup, during a change in spatial configuration, or during a change from single-base to multi-base transmission, for example. Control is then passed to process **1356**. In process **1356** the composite signals are received and appropriately processed by the associated modules of the subscriber unit (see FIG. 3). Control is then passed to decision process **1358**. In decision process **1358**, any training sequences and update of signal processing parameters that may be required are performed. Control is then passed to decision process **1360** for a determination as to whether signal quality and/or strength is adequate. If an affirmative determination is reached, e.g. that quality and/or strength is adequate, then control returns to process **1350** for the processing of the next datastream. Alternately, if a negative determination is reached, then control is passed to process **1362**. In process **1362** signaling of the BTS(s) that signal strength or quality is not acceptable is accomplished. In an embodiment of the invention, the subscriber unit signals the BTS that signal strength is no longer suitable for reception, or that signal separation, in the case of spatial transmissions, is no longer adequate. Control then returns to process **1350** for the processing of the next datastream.

If, alternately, in decision process **1352** the control signal from the BTS indicates that the mode of the incoming composite signals is spatial, control is passed to process **1370**. In process **1370**, control information received by the subscriber unit indicates the number of substreams for which the spatial processor, and other modules of the receive portion of the subscriber unit, are to be configured. Control is then passed to process **1372**. In process **1372** access parameters, e.g. channel, for the transmission from the BTS(s) to the subscriber unit are passed to the subscriber unit. Control then passes to process **1374**. In process **1374** the composite signals are received and processed into corresponding estimated subscriber substreams. Control then passes to decision process **1376**. In decision process **1376** a determination is made as to whether any training sequence is present in the datastream. This embodiment of the invention therefore implements non-blind training. Other embodiments of the invention implementing blind training methods need not implement this particular act. If, in decision process **1376** a negative determination is reached, i.e. that no training sequences are present, control returns to process **1350**. Alternately, if in decision process **1376** an affirmative deter-

mination is reached, i.e. that a training sequence is present, then control is passed to process 1378. In process 1378, evaluation of the training sequence is performed and new weights registered within the spatial/space-time processor for separating the training sequences. Control is then passed to decision process 1380 for evaluation of the training sequences, then passed to decision process 1382 for a determination of whether the training sequences can be separated adequately. If an affirmative decision is reached, then control returns to decision process 1350. Alternately, if the separation is not adequate, then control passes to process 1384. In process 1384, a control signal is sent to the BTS indicating that a change in spatial configuration is required. The BTS(s) might respond by changing spatial configuration from single to multi-base, by changing the number or spatial configuration of the antennas utilized at a single base, by changing a channel, etc. Control then returns to process 1350 for processing of the next datastream.

The foregoing description of a preferred embodiment of the invention has been presented for purposes of illustration and description. It is not intended to be exhaustive or to limit the invention to the precise forms disclosed. Obviously many modifications and variations will be apparent to practitioners skilled in this art. It is intended that the scope of the invention be defined by the following claims and their equivalents.

What is claimed is:

1. A wireless cellular network for transmitting subscriber datastreams to corresponding ones among a plurality of subscriber units located within the cellular network, and said wireless cellular network comprising:

base stations each including spatially separate transmitters for transmitting in response to control signals, selected substreams of each subscriber datastream on an assigned channel of a multiple access protocol; and logic communicating with each of the base stations and the logic for assigning an available channel on which to transmit each subscriber datastream, for routing at least a substream of each datastream to at least a selected one of the base stations and for generating control signals to configure the at least a selected one of the base stations to transmit the selected substreams to a corresponding one among the plurality of subscriber units on the assigned channel.

2. The wireless cellular network of claim 1, wherein the multiple access protocol is selected from at least one of a group of multiple access protocols consisting of: code-division multiple access, frequency-division multiple access, time-division multiple access, space-division multiple access, orthogonal frequency division multiple access (OFDMA), wavelength division multiple access (WDMA), wavelet division multiple access, orthogonal division multiple access (ODMA) and quasi-orthogonal division multiple access (ODMA) techniques.

3. The wireless cellular network of claim 1, wherein the assigned channel comprises, within a transmission bandwidth, at least one of: a frequency-division, a time-division, a spatial-division, a code-division, orthogonal frequency division multiple access (OFDMA), wavelength division multiple access (WDMA), wavelet division multiple access or any other orthogonal division multiple access (ODMA)/quasi-orthogonal division multiple access techniques.

4. The wireless cellular network of claim 1, wherein the logic further communicates with at least one of a group of networks for delivering the subscriber datastreams, and the group of networks consisting of: a public switched telephone

network, public land mobile network, a local area network, a wide area network, a satellite network, an adhoc network, a virtual private network, an intranet and an internet.

5. The wireless cellular network of claim 1, wherein the base stations are fixed.

6. The wireless cellular network of claim 1, wherein the base stations are mobile.

7. The wireless cellular network of claim 1, wherein the base stations include satellites.

8. The logic of claim 1, further for changing a spatial transmission configuration from a first transmitting base station to at least the first base station together with a second transmitting base station responsive to a determination that a change of a spatial reception configuration is required in order to resolve the selected substreams at the corresponding one among the plurality of subscriber units.

9. The logic of claim 1, further for changing the spatial reception configuration from a first receiving base station to at least a second base station together with a third base station responsive to a determination that a change of a spatial reception configuration is required in order to resolve the selected substreams at the corresponding one among the plurality of subscriber units.

10. The wireless cellular network of claim 1, wherein the logic further comprises:

a parser for parsing each datastream into substreams.

11. The wireless cellular network of claim 10, wherein the parser includes responsiveness to a mode signal to parse each datastream into a variable number of substreams and to avoid parsing of each datastream.

12. The wireless cellular network of claim 10, wherein the parser includes responsiveness to a modulation rate of each substream.

13. The wireless cellular network of claim 1, wherein the logic further comprises:

a parser for parsing each datastream into substreams; and a router for routing the substreams to at least a selected one of the base stations.

14. The wireless cellular network of claim 13, wherein each of the base stations further comprises:

a selector responsive to the control signals generated by the logic to inject a routed one of the substreams onto the channel assigned by the logic.

15. The wireless cellular network of claim 13, wherein each of the base stations further comprises:

a selector responsive to the control signals generated by the logic to inject routed ones of the substreams onto both the channel assigned by the logic as well as onto selected ones of the spatially separate transmitters.

16. The wireless cellular network of claim 1, wherein the logic further comprises:

a detector to detect modes of the subscriber datastreams from the first network and to generate a mode signal corresponding to the mode of each of the subscriber datastreams;

a parser responsive to the mode signal to parse the datastream into a variable number of substreams and to avoid parsing of the datastream; and

a router for routing both an unparsed datastream as well as a variable number of substreams to at least a selected one of the base stations.

17. The wireless cellular network of claim 16, wherein the modes of the datastreams include voice mode and data mode and wherein the parser responsive to a voice mode signal avoids parsing of the datastream, and responsive to a data mode signal parses the datastream into a variable number of substreams.

18. The wireless cellular network of claim 16, wherein the modes of the datastreams include high bit rate and low bit rate and wherein further the parser avoids parsing of a low bit rate datastream, and parses a high bit rate datastream into a variable number of substreams.

19. The wireless cellular network of claim 16, wherein the modes of the datastreams include low QoS requirement and high QoS requirement and wherein further the parser avoids parsing a datastream with a low QoS requirement, and parses a datastream with a high QoS requirement into a variable number of substreams.

20. The wireless cellular network of claim 16, wherein each of the base stations further comprises:

a selector responsive to the control signals generated by the logic to inject routed ones of the variable number of substreams as well as the unparsed datastream onto the channel assigned by the logic.

21. The wireless cellular network of claim 16, wherein each of the base stations further comprises:

a selector responsive to the control signals generated by the logic to inject routed ones of the substreams as well as the unparsed datastream onto both the channel assigned by the logic as well as a selected one of the spatially separate transmitters.

22. The wireless cellular network of claim 1, wherein the logic further comprises:

a router for routing each of the subscriber datastreams to at least a selected one of the base stations; and wherein each of the base stations further comprises:

a parser for receiving the subscriber datastream and for parsing the subscriber datastream into the selected substreams.

23. The wireless cellular network of claim 22, wherein the parser includes responsiveness to the control signals generated by the logic to parse the datastream into a variable number of substreams.

24. The wireless cellular network of claim 22, wherein each of the base stations further comprises:

a selector communicating with the parser and the selector responsive to the control signals generated by the logic to inject the selected substreams onto the channel assigned by the logic.

25. The wireless cellular network of claim 22, wherein each of the base stations further comprises:

a selector communicating with the parser and the selector responsive to the control signals generated by the logic to inject the selected substreams onto both the channel assigned by the logic as well as a selected one of the spatially separate transmitters.

26. The wireless cellular network of claim 1, wherein the logic further comprises:

a detector to detect modes of the subscriber and to generate a mode signal corresponding to the mode of each of the subscriber datastreams;

a router for routing to at least a selected one of the base stations each of the subscriber datastreams; and

wherein each of the base stations further comprises:

a parser for receiving the subscriber datastream and responsive to the mode signal to parse the datastream into a variable number of substreams and to avoid parsing of the datastream.

27. The wireless cellular network of claim 26, wherein the modes of the datastreams include voice mode and data mode, and wherein further the parser responsive to a voice mode signal avoids parsing of the datastream, and responsive to a data mode signal parses the datastream into a variable number of substreams.

28. The wireless cellular network of claim 26, wherein the modes of the datastreams include high baud rate and low baud rate and wherein further the parser responsive to a low baud rate signal avoids parsing of the datastream, and responsive to a high baud rate signal parses the datastream into a variable number of substreams.

29. The wireless cellular network of claim 26, wherein each of the base stations further comprises:

a selector communicating with the parser and the selector responsive to the control signals generated by the logic to inject one of the unparsed datastream and the variable number of substreams onto the channel assigned by the logic.

30. The wireless cellular network of claim 26, wherein each of the base stations further comprises:

a selector responsive to the control signals generated by the logic to inject one of the unparsed datastream and the variable number of substreams onto both the channel assigned by the logic as well as a selected one of the spatially separate transmitters.

31. The wireless cellular network of claim 1, wherein each of the base stations further comprises:

a training module for injecting a training sequence into the transmissions of the spatially separable transmitters.

32. The wireless cellular network of claim 31, wherein the training module further comprises:

a logic for varying at least one of: a duration of the training sequence and a frequency of the training sequence.

33. The wireless cellular network of claim 31, wherein the training module further comprises:

a logic for selecting a training sequence.

34. The wireless cellular network of claim 1, wherein each of the base stations further comprises:

spatially separate receivers for receiving composite signals resulting from the spatially separate transmission of spatially separate source signals corresponding to selected substreams of an uplink subscriber datastream from selected ones of the subscriber units, on an assigned channel of the multiple access protocol;

a spatial processor configurable in response to the control signal to separate the composite signals into estimated source signals based on information obtained during the transmission of known data patterns from the selected ones of the subscriber units; and

a combiner for combining the estimated source signals into a corresponding uplink subscriber datastream.

35. The wireless cellular network of claim 34, wherein the spatial processor further comprises:

a configurable logic responsive to the control signal to vary both a number of the composite signals separated as well as the number of the estimated source signals.

36. The wireless cellular network of claim 35, wherein the configurable logic further comprises:

logic for evaluating the composite signals over time.

37. The wireless cellular network of claim 1, wherein each of the base stations further comprise:

mobility detectors for determining a mobility of each of the subscriber units and generating a mobility signal; and

a training module responsive to the mobility signal for varying at least one of: an injection interval and duration of a training sequence into the transmissions of the spatially separable transmitters.

38. The wireless cellular network of claim 1, wherein each of the base stations further comprises:

transmit processes selected from at least one of a group of transmit processes consisting of: diversity, space coding, space time coding and beam forming.

39. A wireless cellular network for transmitting subscriber downlink datastreams from a first network to subscribers located within the wireless cellular network, and said wireless cellular network comprising:

base stations each configured for spatially separate transmission of selected substreams of each subscriber downlink datastream on an assigned channel of a multiple access protocol;

subscriber units each configured for spatially separate reception on the assigned channel of the selected substreams and for combining the substreams into the corresponding subscriber datastream; and

a logic communicating with each of the base stations and to the first network and the logic configured to route at least a substream of each subscriber downlink datastream to at least a selected one of the base stations and further configured to vary the routing between a single base station and multiple base stations to vary a spatial transmission configuration of the selected substreams.

40. A wireless cellular network for receiving subscriber datastreams at corresponding ones among a plurality of base stations located within the cellular network, and said wireless cellular network comprising:

a plurality of subscriber units each including spatially separate transmitters for transmitting, in response to control signals, selected substreams of each subscriber datastream on an assigned channel of a multiple access protocol; and

logic communicating with each of the base stations and the logic for generating control signals to configure selected ones of the base stations to receive composite signals resulting from the spatially separate transmission of the selected substreams from a corresponding one among the plurality of subscriber units on the assigned channel, for converting the composite signals into estimate substreams and for combining the estimated substreams of each subscriber datastream into each subscriber datastream.

41. The logic of claim 40, further for changing the spatial reception configuration from a first receiving base station to at least the first base station together with a second base station responsive to a determination that a change of a spatial reception configuration is required in order to resolve the composite signals into estimated substreams.

42. The logic of claim 40, further for changing the spatial reception configuration from a first receiving base station to at least a second base station together with a third base

station responsive to a determination that a change of a spatial reception configuration is required in order to resolve the composite signals into estimated substreams.

43. A wireless cellular network for transmitting subscriber datastreams to corresponding ones among a plurality of subscriber units located within the cellular network, and said wireless cellular network comprising:

base stations each including at least one transmitter for transmitting, in response to control signals, selected substreams of each subscriber datastream on an assigned channel of a multiple access protocol; and

logic communicating with each of the base stations and the logic for assigning an available channel on which to transmit each subscriber datastream, for routing at least a substream of each datastream to at least a selected one of the base stations and for generating control signals to configure the at least a selected one of the base stations to transmit the selected substreams to a corresponding one among the plurality of subscriber units on the assigned channel.

44. The logic of claim 43, further for changing a spatial transmission configuration from a first transmitting base station to at least the first base station together with a second transmitting base station responsive to a determination that a change of a spatial reception configuration is required in order to resolve the selected substreams at the corresponding one among the plurality of subscriber units.

45. The logic of claim 43, further for changing the spatial reception configuration from a first receiving base station to at least a second base station together with a third base station responsive to a determination that a change of a spatial reception configuration is required in order to resolve the selected substreams at the corresponding one among the plurality of subscriber units.

46. The logic of claim 43, further for changing a spatial transmission configuration from a first transmitting base station together with a second transmitting base station to at least the first transmitting base station together with a third transmitting base station responsive to a determination that a change of a spatial reception configuration is required in order to resolve the selected substreams at the corresponding one among the plurality of subscriber units.

47. The logic of claim 43, further for changing a spatial transmission configuration from a first transmitting base station together with a second transmitting base station to at least the third transmitting base station together with a fourth transmitting base station responsive to a determination that a change of a spatial reception configuration is required in order to resolve the selected substreams at the corresponding one among the plurality of subscriber units.